

Applications:

Automatic clamping of dies

- ▶ on press rams
- ▶ on hold-down devices
- ▶ at max. ambient temperatures of 70°C

Function:

The rotation of the motor is converted into a swivelling movement and a stroke of the tie rod by the flexspine gear and the lead screw. For clamping, the tie rod is swivelled by 90°, starting at the unclamping position, and pulled towards the clamping position. The clamping force and the clamping and unclamping positions are monitored by inductive proximity switches. The clamping force is maintained by self-locking.

Special features:

- ▶ Clamping stroke up to 15 mm, which means high adaptability to varying heights of clamping edges
- ▶ Position monitoring and an automatic cycle ensure high operational reliability
- ▶ Central operation of all clamping elements
- ▶ Compact design, rugged construction
- ▶ Variable length of tie rod
- ▶ Resistant to high mechanical loads
- ▶ Shock-resistant up to a max. ram acceleration of 12 g
- ▶ Suitable for retrofit and for installation in original equipment



Electromechanical swivel and pull clamping elements mounted on a transfer press.



Swivel and pull clamping element electromechanical

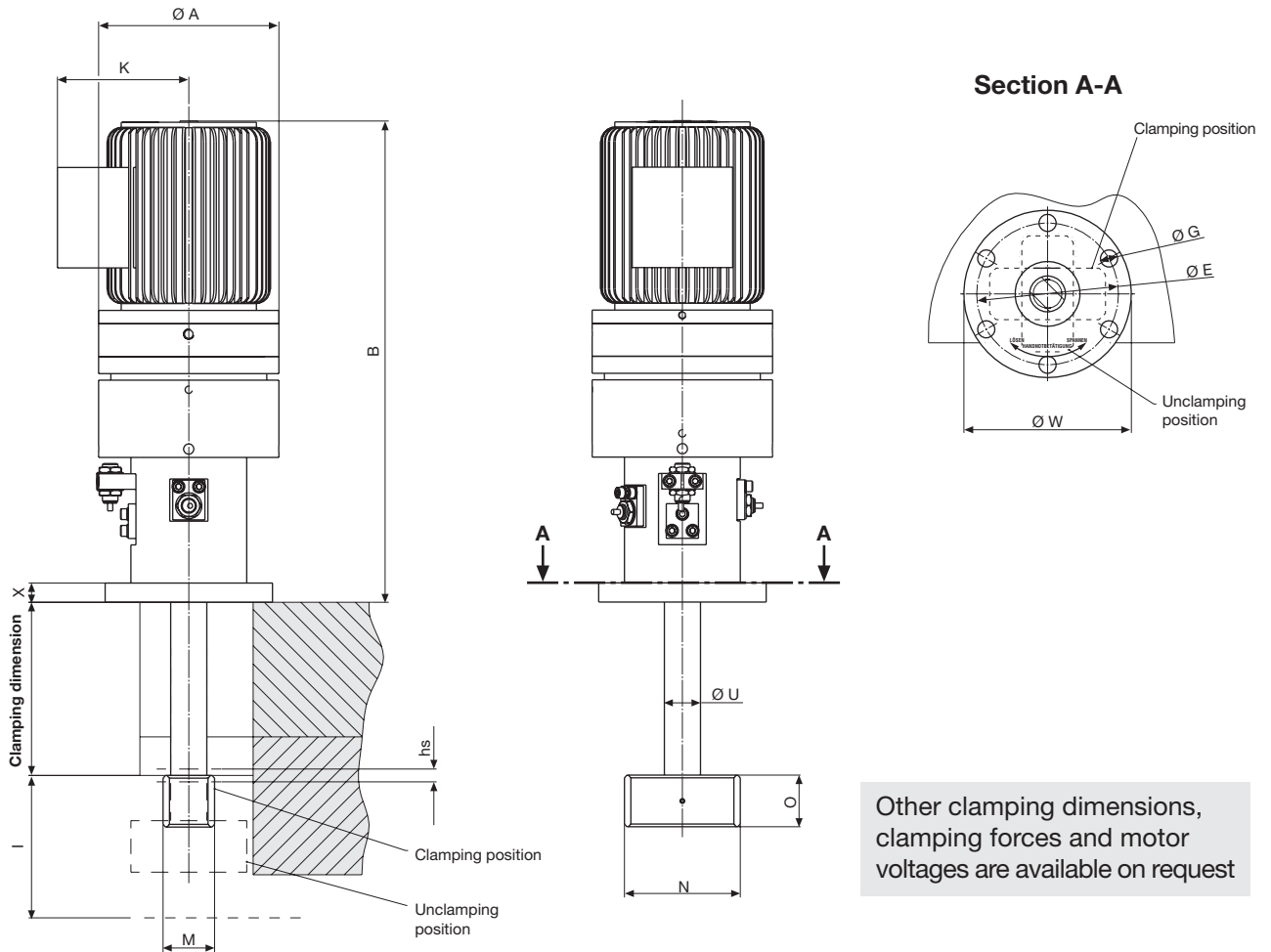

Dimensions in mm

Type	A	B	E	G	Clamping stroke hs	Swiveling stroke	Installation space l	K	M	N	O	U	W	X
8.2643.0101	140	374	110	13,5	10	25	90	102,0	40	90	40	28	130	15
8.2645.0101	160	441	140	13,5	10	30	115	112,5	50	90	60	40	160	20
8.2646.0101	195	500	160	13,5	15	40	135	112,5	60	90	65	40	180	20

Clamping dimension to be quoted in the order

Technical data

Type	Clamping force	Max. static force	Clamping speed	Connected motor voltage	Motor rating	Rated motor current
8.2643.0101	70 kN	110 kN	3,8 mm/s	400V/ 50Hz	0,55 kW	2,1 A
8.2645.0101	120 kN	200 kN	5,7 mm/s	400V/ 50Hz	1,1 kW	3,55 A
8.2646.0101	160 kN	300 kN	4,1 mm/s	400V/ 50Hz	1,1 kW	3,55 A

Terminal connections

