

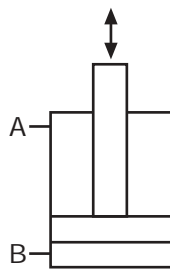

Pull clamping element double-acting



Applications:

- ▶ integrated in press rams
- ▶ integrated in press bed
- ▶ in machine tools and equipment
- ▶ when the available space is limited

Function:

Double acting pull clamping element for clamping dies on a press bed or press ram. The die must be provided with T-slots for the tie rod. It is important that the die is correctly pushed into the press, and is parallel with the clamping elements. The clamping and unclamping positions are monitored by inductive proximity switches. The tie rod and the piston are hardened and ground, and the hydraulic system is protected against dirt by wiper rings.

Special features:

- ▶ Position monitoring ensures high functional safety
- ▶ Ideal power transmission with centrally arranged clamping elements
- ▶ Compact design
- ▶ Clamping force of between 60 and 164 kN
- ▶ Optimum use of bed and ram surfaces
- ▶ Die clamping in barely accessible positions
- ▶ Compensates for large clamping edge tolerances (± 1.5 mm)

For power units

please see product group 7

For accessories

please see product group 11



Pull clamping elements in the press bed of a double column press. Easy die positioning is ensured by roller blocs in the T-slots of the press bed.

Pull clamping element double-acting



HILMA

Pulling force at 400 bar (kN)	60	104	164
Pulling force at 100 bar (kN)	15	26	41
Piston-Ø e (mm)	54	70	88
Piston rod-Ø d (mm)	32	40	50
Max. stroke h (mm)	10	10	10
Oil consumption cl. (cm ³)	10	16	25
Oil consumption uncl. (cm ³)	15	23	37
a (mm)	128	160	192
b (mm)	84	104	122
c (mm)	82	104	126
f (mm)	M24x1,5	M30x1,5	M36 x 1,5
g	G 1/4	G 3/8	G 3/8
i (mm)	6	6	6
k (mm)	13	17	21
l (mm)	26	35	41
m (mm)	28	37	48
n (mm)	51	68	85
o (mm)	20	26	33
p (mm)	13	18	22
q (mm)	□ 52	Ø 74	□ 84
r (mm)	65	74	95
s (mm)	58	82	92
t (mm)	104	130	156
u (mm)	30	38	45
v (mm)	20	28	35
w (mm)	38	48	58
x (mm)	5,5	8	8
Weight (kg)	4,4	9	15
Part no.			
with pipe connection	2184-160	2185-160	2186-160
with flanged connection	2184-200	2185-200	2186-200

Max. operating pressure 400 bar

Other sizes and special versions are available on request.

Please note!

The piston rod is made from tempered steel. In the case of aggressive ambient conditions, a special material will be required.

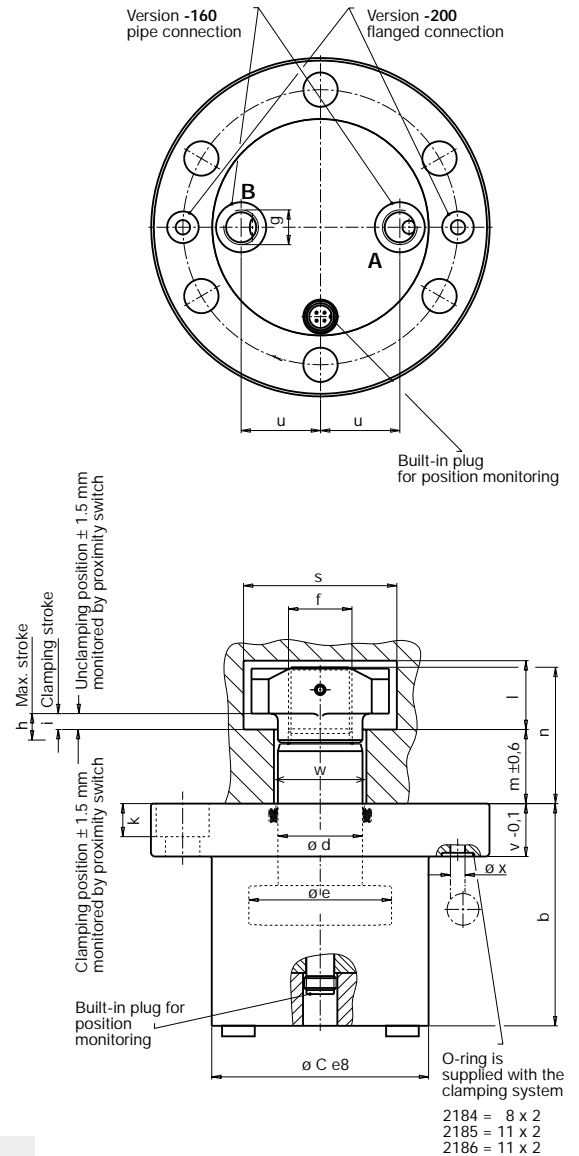

Clamping of a complete die changing table with pull clamping elements.

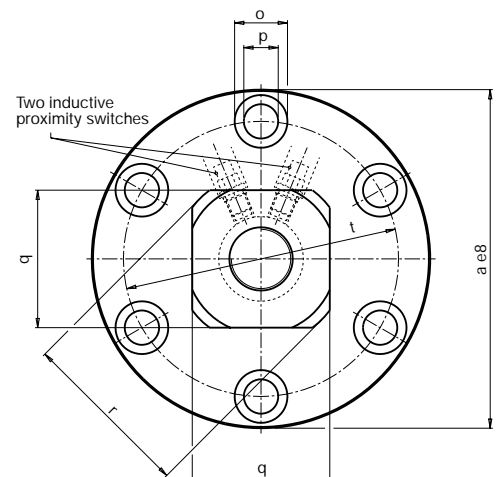



Recommended installation

In order to ensure ease of servicing, two alternatives are offered for connecting the pull clamps.

Flanged connection

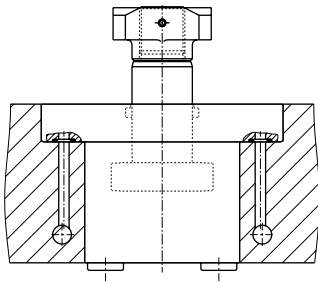

Hydraulic oil is fed through the drilled holes in the bed and in the ram. There are no exposed conduits or screw fittings.

O-rings supplied with the clamping element provide for tight fitting. Easy installation, ease of servicing.

Pipe connection

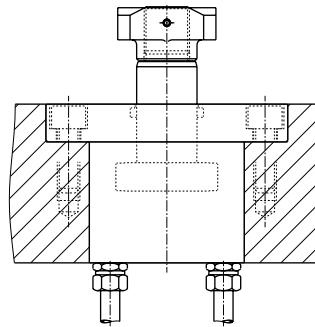

Pipes are recommended in applications where screw fittings are easily accessible and where pipes do not impede installation and dismantling of the pull clamping elements.

Drilled hole for flanged or pipe connection

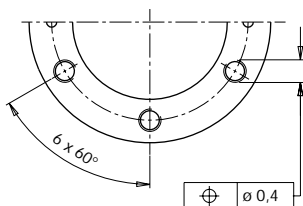
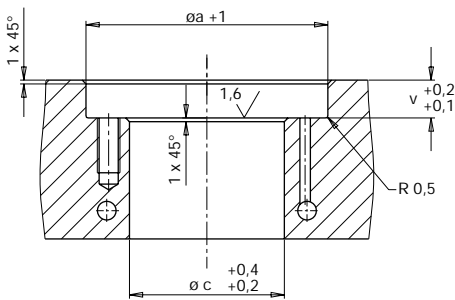

Connection of the monitoring system for clamping and unclamping position

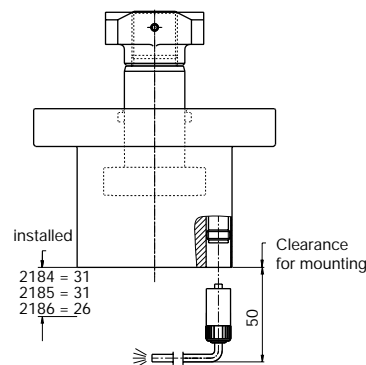

Both proximity switches are connected to the base of the pull clamp through a connecting lead with a screw coupling [IP 67]. The connecting lead must be ordered separately. Further installation may be carried out using a distribution block with an LED display, see page 19

Flanged connection requires a plain and neat surface.

Pull clamping element double-acting



HILMA

Electrical installation

Pin assignment for three-wire proximity switches

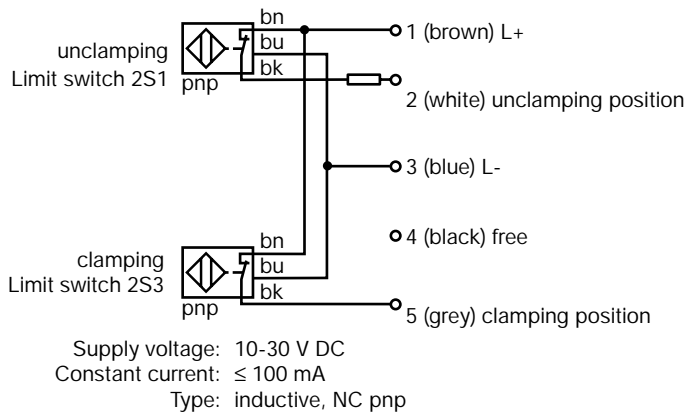

5-pole connecting lead with screw coupling

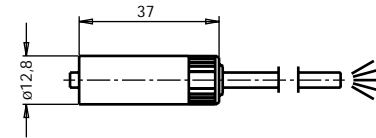

Cable length 5 m **Part no. 5700-013**
Cable length 10 m **Part no. 5700-014**

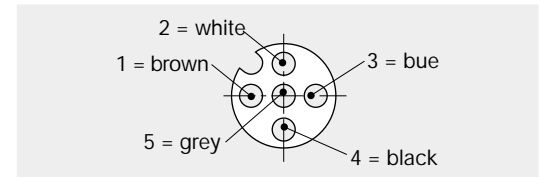

Distribution block with LED display for connecting 4 clamping elements

Easy installation!

LED display of the unclamping, change-over and clamping position of each clamping element.

Scope of delivery: 1 distribution block
4 coupler plugs, 5 poles
1 coupler plug, 16 poles

Wiring of output plug:

Pin 1 = L+ Pin 15 = free
Pin 2 = L- Pin 16 = free
Pin 3 = 1L
Pin 4 = do not use
Pin 5 = 1S
Pin 6 = 2L
Pin 7 = do not use
Pin 8 = 2S
Pin 9 = 3L
Pin 10 = do not use
Pin 11 = 3S
Pin 12 = 4L
Pin 13 = do not use
Pin 14 = 4S

L = Unclamping position
U = not assigned
S = Clamping position

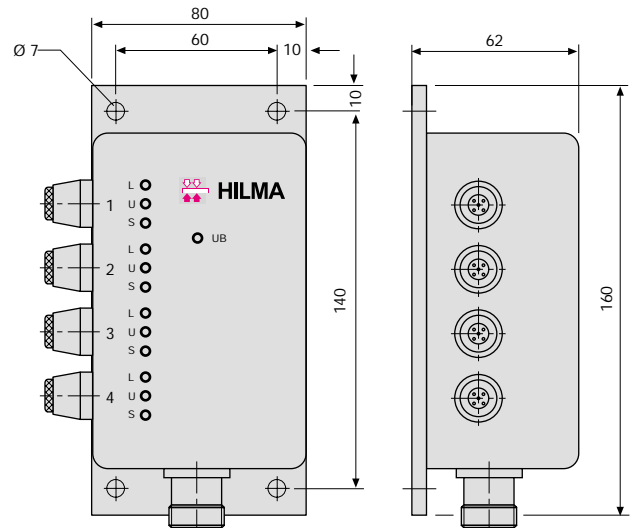

Part no. 5700-015

Hydraulic installation

Read the operating instructions before commissioning the system.

Other parameters and recommendations are given in chapter no. 1 "General information".