

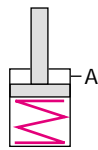

Applications:

- for clamping dies on press bed and press slide when the available space is limited

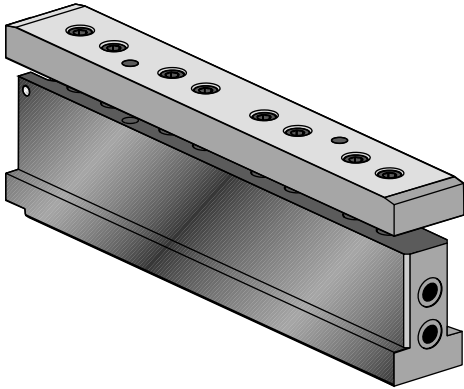

Double-T clamping bar, single-acting with spring return, without support rollers: usually for use in a press slide but also suitable for use in a press bed.

The double-T clamping bar is installed by pushing it into the T-slots of the press slide or the press bed in any desired position. The bar is manually secured in position using locking screws in the root of the T-slot.

The double-T design requires T-slots in the die and in the press slide or press bed. The clamping force is generated by applying hydraulic pressure to the pistons, and unclamping is carried out mechanically by spring return.

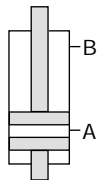
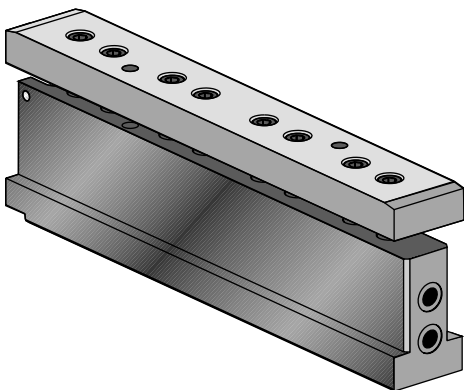

Double-T clamping bar, double-acting, without support rollers: usually for use in a press slide but also suitable for use in a press bed.

Installation of the double-T clamping bar and generation of the clamping force are as described above, but with one additional clamping circuit for unclamping. The bar is automatically secured in position using locking pistons in the root of the T-slot.

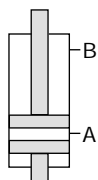
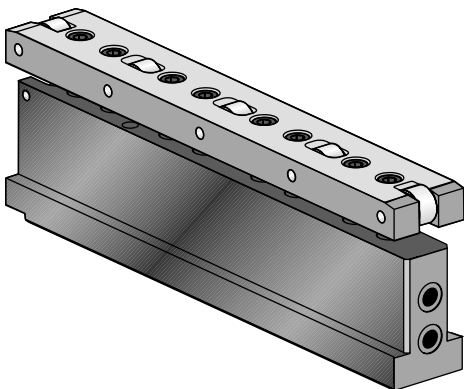

Double-T clamping bar, double-acting with support rollers for lifting and clamping: usually for use in a press bed.

Installation and generation of the clamping force are as described above, but with additional support rollers. A double-acting piston causes the support rollers to lift the die and to be clamped by a second clamping circuit. Before clamping the die is placed on the support rollers, since it is not in contact with the press bed, it can easily be moved in a linear direction and be positioned.

Lifting, moving, positioning and clamping uses only one element.

Since double-T bars are composed of modular segments, various lengths are available.

Special features:

- max. operating pressure 400 bar, therefore no low-pressure circuit is required
- the complete clamping surface can be used
- no collision edges
- easy and quick retrofit
- ideal, uniform power transmission.



Double-T clamping bar single-acting with spring return

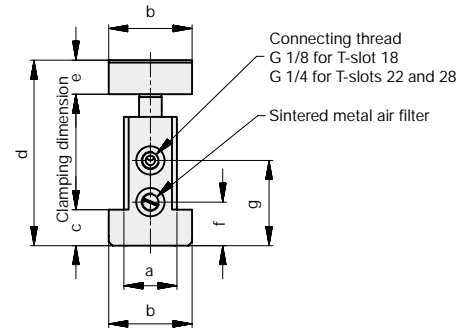
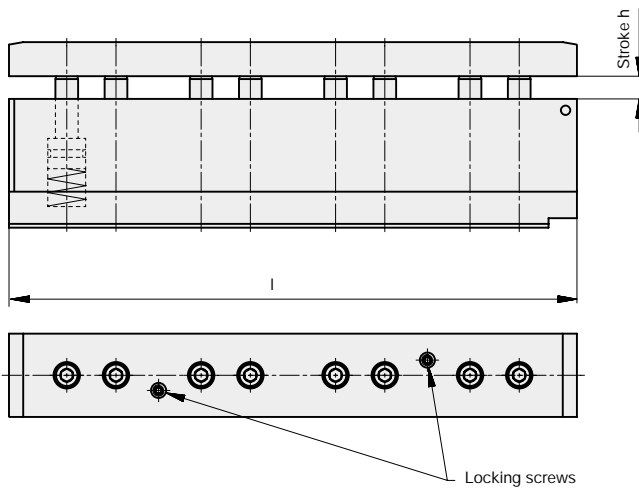

Slot (a) (mm)	b (mm)	c (mm)	d min (mm)	d max (mm)	e (mm)	g (mm)	Clamping dimension (mm)	Stroke h* (mm)	Max. operating pressure (bar)
18	28	11,5	55	63	11	30,5	33,5 + 6	8	400
22	35	15,0	70	80	15	41,0	41,0 + 8	10	400
28	44	19,0	89	101	18	46,0	53,0 + 10	12	400

* Reduction of stroke on request

Part no.	T-slot (a) (mm)	Length (l)* (mm)	Clamping force (kN) at 400 bar	Oil consumption clamping (cm ³)
8.1832.1810	18	150	16,6	33,3
8.1832.1812	18	300	33,2	66,6
8.1832.1814	18	450	49,8	99,9
8.1832.1816	18	600	66,4	132,2
8.1832.1818	18	750	83,0	166,5
8.1832.2210	22	300	39,2	98,0
8.1832.2212	22	600	78,4	196,0
8.1832.2214	22	900	117,6	294,0
8.1832.2216	22	1200	156,8	392,0
8.1832.2218	22	1500	196,0	490,0
8.1832.2810	28	300	64,0	193,0
8.1832.2812	28	600	128,0	386,0
8.1832.2814	28	900	192,0	579,0
8.1832.2816	28	1200	256,0	772,0
8.1832.2818	28	1500	320,0	965,0

* Intermediate length dimensions and extra-long bars are available on request.

The double-T clamping bars are composed of individual segments. When clamping or unclamping, make sure that there is an overlap of >50% of the length of the segment.

Length of

the segment: T-slot 18 $\hat{=}$ 150 mm
 T-slot 22 $\hat{=}$ 300 mm
 T-slot 28 $\hat{=}$ 300 mm



Double-T clamping bar on press bed and press slide

Double-T clamping bar double-acting

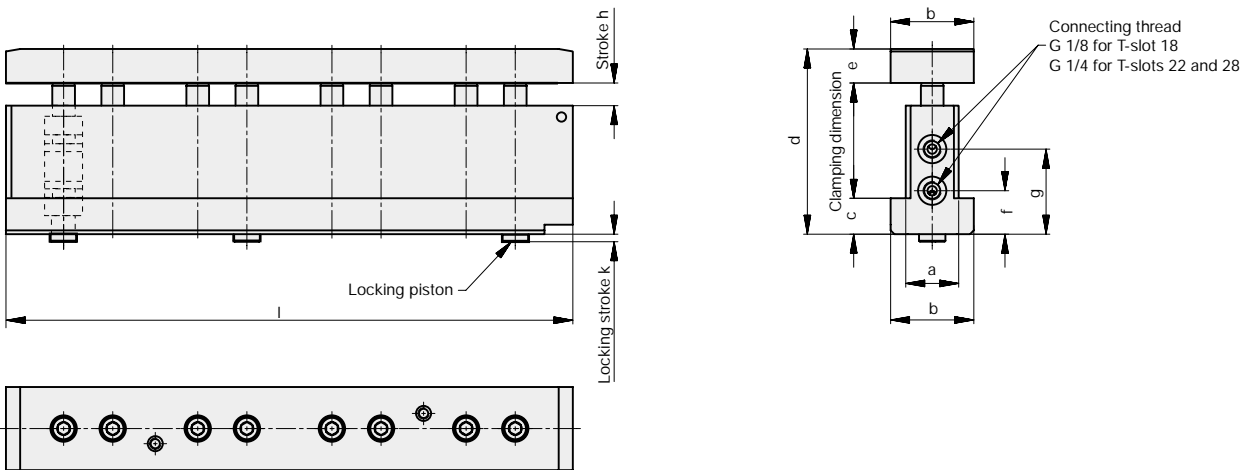

Slot (a) (mm)	b (mm)	c (mm)	d min (mm)	d max (mm)	e (mm)	f (mm)	g (mm)	Clamping dimension (mm)	Stroke h* (mm)	Locking stroke k** (mm)	Max. operating pressure (bar)
18	28	11,5	55	63	11	13,5	30,5	33,5 + 6	8	2,5	400
22	35	15,0	70	80	15	18,0	41,0	41,0 + 8	10	3,0	400
28	44	19,0	89	101	18	23,0	46,0	53,0 +10	12	4,0	400

* Reduced stroke is available on request

** Locking screw (see double-T bar single-acting) instead of locking piston is available on request.

Part no.	T-slot (a) (mm)	Length (l)* (mm)	Clamping force (kN) at 400 bar		Oil consumption (cm ³) clamping unclamp.	
8.1832.1820	18	150	16,6	33,3	64,7	
8.1832.1822	18	300	33,2	66,6	129,4	
8.1832.1824	18	450	49,8	99,9	194,1	
8.1832.1826	18	600	66,4	133,2	258,8	
8.1832.1828	18	750	83,0	166,5	323,5	
8.1832.2220	22	300	39,2	98,0	209,0	
8.1832.2222	22	600	78,4	196,0	418,0	
8.1832.2224	22	900	117,6	294,0	627,0	
8.1832.2226	22	1200	156,8	392,0	836,0	
8.1832.2228	22	1500	196,0	490,0	1045,0	
8.1832.2820	28	300	64,0	193,0	402,0	
8.1832.2822	28	600	128,0	386,0	804,0	
8.1832.2824	28	900	192,0	579,0	1206,0	
8.1832.2826	28	1200	256,0	772,0	1608,0	
8.1832.2828	28	1500	320,0	965,0	2010,0	

The double-T clamping bars are composed of individual segments. When clamping or unclamping, make sure that there is an overlap of >50% of the length of the segment.

Length of the segment: T-slot 18 $\hat{=}$ 150 mm
T-slot 22 $\hat{=}$ 300 mm
T-slot 28 $\hat{=}$ 300 mm

* Intermediate length dimensions and extra-long bars are available on request.

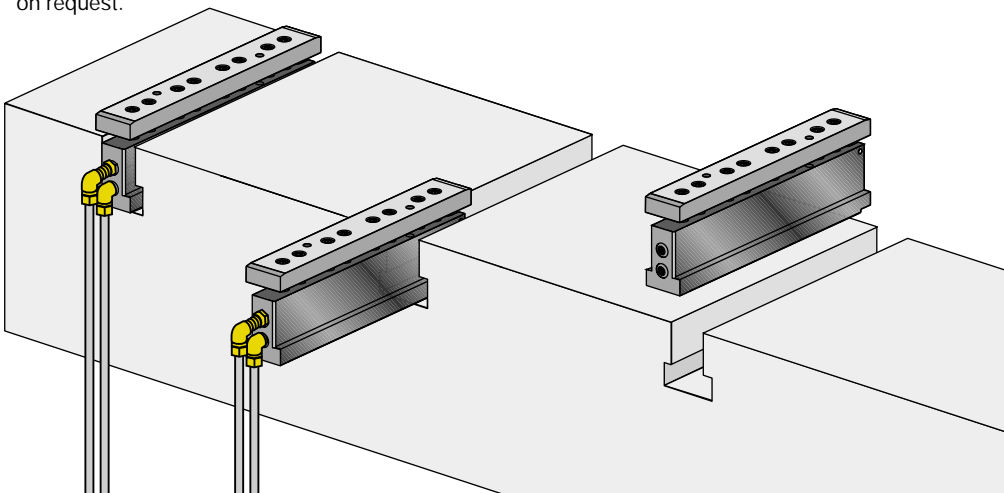

Double-T clamping bar double-acting lifting and clamping

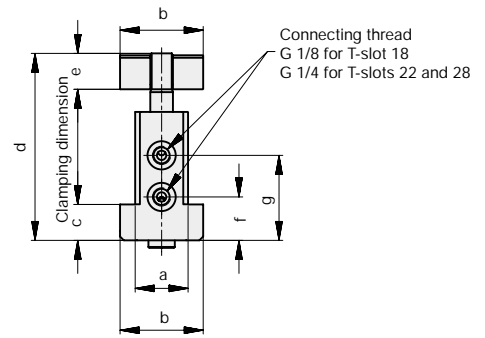
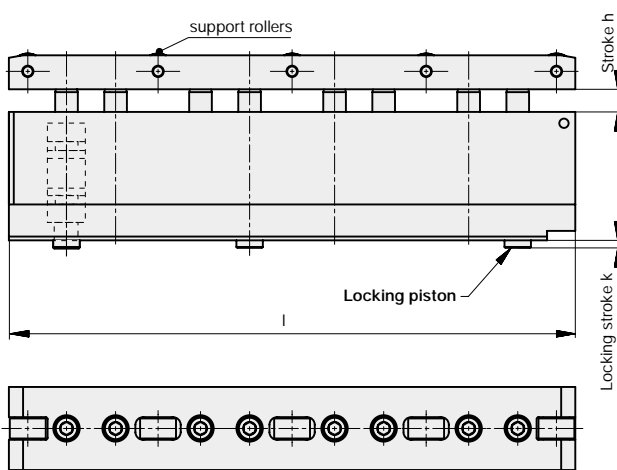

Slot (a) (mm)	b (mm)	c (mm)	d min (mm)	d max (mm)	e (mm)	f (mm)	g (mm)	Clamping dimension (mm)	Stroke h* (mm)	Locking stroke k (mm)	Max. operating pressure (bar)
18	28	11,5	56	64	12	13,5	30,5	33,5 + 6	8	2,5	400
22	35	15,0	71	80	16	18,0	41,0	41,0 + 8	10	3,0	400
28	44	19,0	90	102	19	23,0	46,0	53,0 + 10	12	4,0	400

* Reduced stroke is available on request

Part no.	T-slot (a) (mm)	Length (l)* (mm)	Load-bearing capacity (kN) at 400 bar	Clamping force (kN) at 400 bar	Number of support rollers	Oil consumption clamping (cm ³)	Oil consumption unclamp. (cm ³)
8.1832.1830	18	150	9	16,6	3	33,3	64,7
8.1832.1832	18	300	18	33,2	6	66,6	129,4
8.1832.1834	18	450	27	49,8	9	99,9	194,1
8.1832.1836	18	600	36	66,4	12	133,2	258,8
8.1832.1838	18	750	45	83,0	15	166,5	323,5
8.1832.2230	22	300	32	39,2	5	98,0	209,0
8.1832.2232	22	600	64	78,4	10	196,0	418,0
8.1832.2234	22	900	96	117,6	15	294,0	627,0
8.1832.2236	22	1200	128	156,8	20	392,0	836,0
8.1832.2238	22	1500	160	196,0	25	490,0	1045,0
8.1832.2830	28	300	37,5	64,0	5	193,0	402,0
8.1832.2832	28	600	75,0	128,0	10	386,0	804,0
8.1832.2834	28	900	112,5	192,0	15	579,0	1206,0
8.1832.2836	28	1200	150,0	256,0	20	772,0	1608,0
8.1832.2838	28	1500	187,5	320,0	25	965,0	2010,0

* Intermediate length dimensions and extra-long bars are available on request.

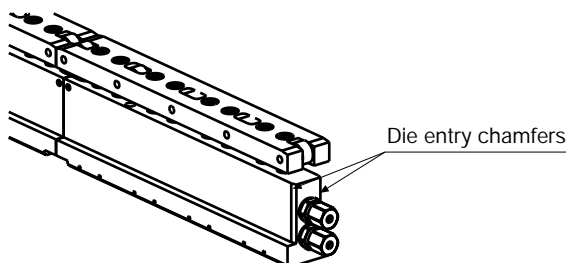

If the dies have a slight lateral offset when loading into the machine, the double-T clamping bars are protected by die entry chamfers at the connection end.

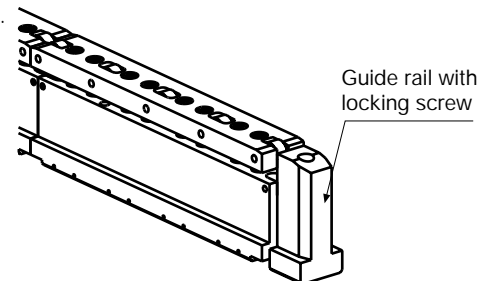

If the lateral offset of the dies is more significant (up to 1.5 mm), or if the dies are not loaded into the machine at the connection end of the double-T clamping bars, it is recommended that separate guide rails are used. They are fastened in the T-slot using clamping bolts. Special guide bar designs are available on request (e.g. with hydraulic ports for the connection end).

- Guide rail for slot T 18 **7.1832.0015**
- Guide rail for slot T 22 **7.1832.0016**
- Guide rail for slot T 28 **7.1832.0017**