

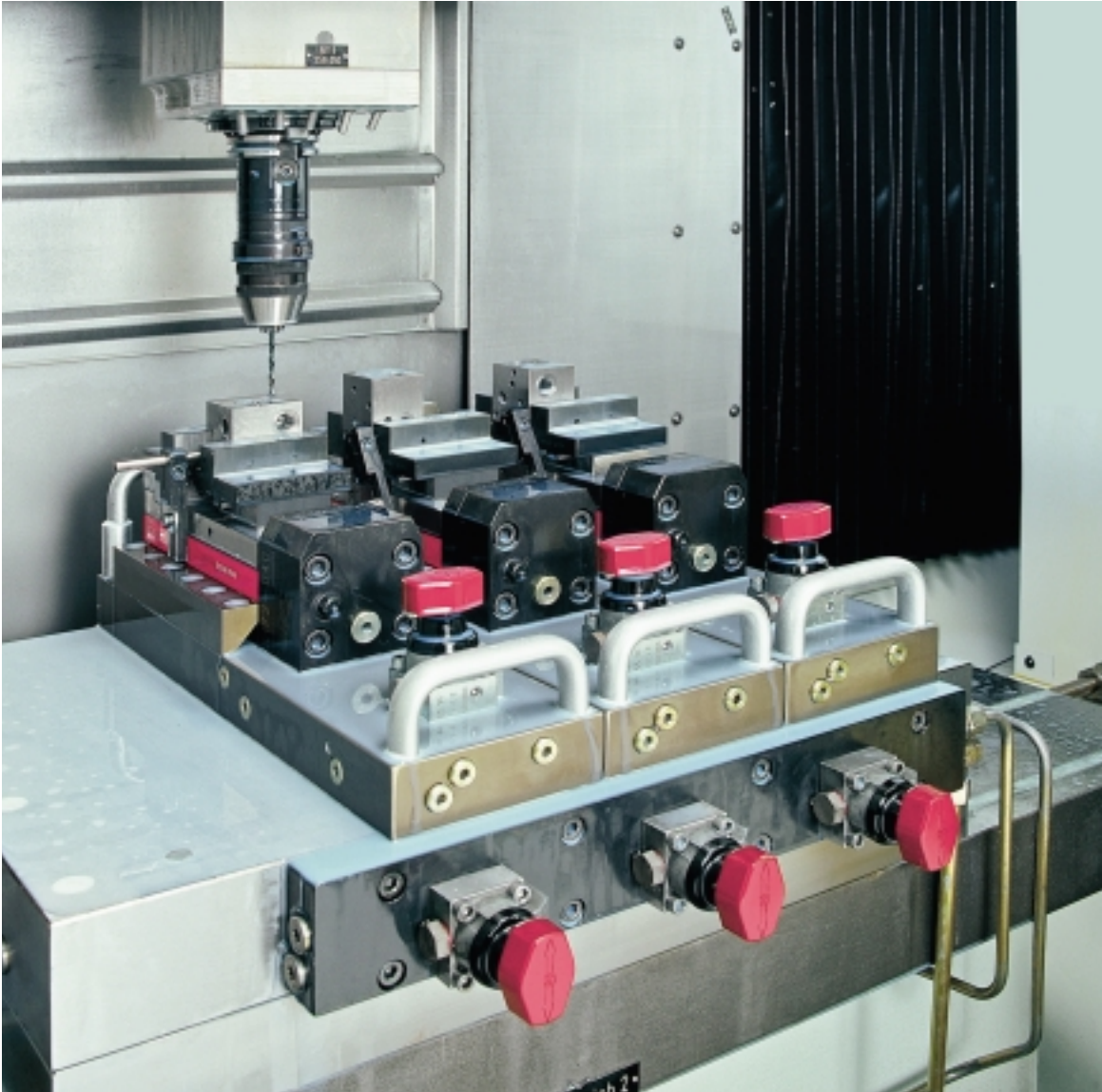

Compact clamping system DUO, CS, DCS



Compact clamping system, combined with interchangeable jaws, provides an efficient means of carrying out many simple and complex clamping tasks.

It is ideally suited for both single-piece and series production and as a structural component of jigs and fixtures.

Various designs and lengths permit an optimum adaptation to the working area, the workpiece and the machining task.

- ❖ Rapid and easy clamping and unclamping by a short lever movement or by operation of a hand or foot switch (hydraulic model)
- ❖ Simple adaptation of standard and special jaws, rapid jaw change
- ❖ A staggered jaw width of between 25 and 80 mm enables several sides of a workpiece to be machined in one clamping operation, even when the workpieces are very small
- ❖ Precisely adjustable and exactly reproducible clamping forces
- ❖ Ideally suited for use with zero point clamping systems
- ❖ Can be installed in any position

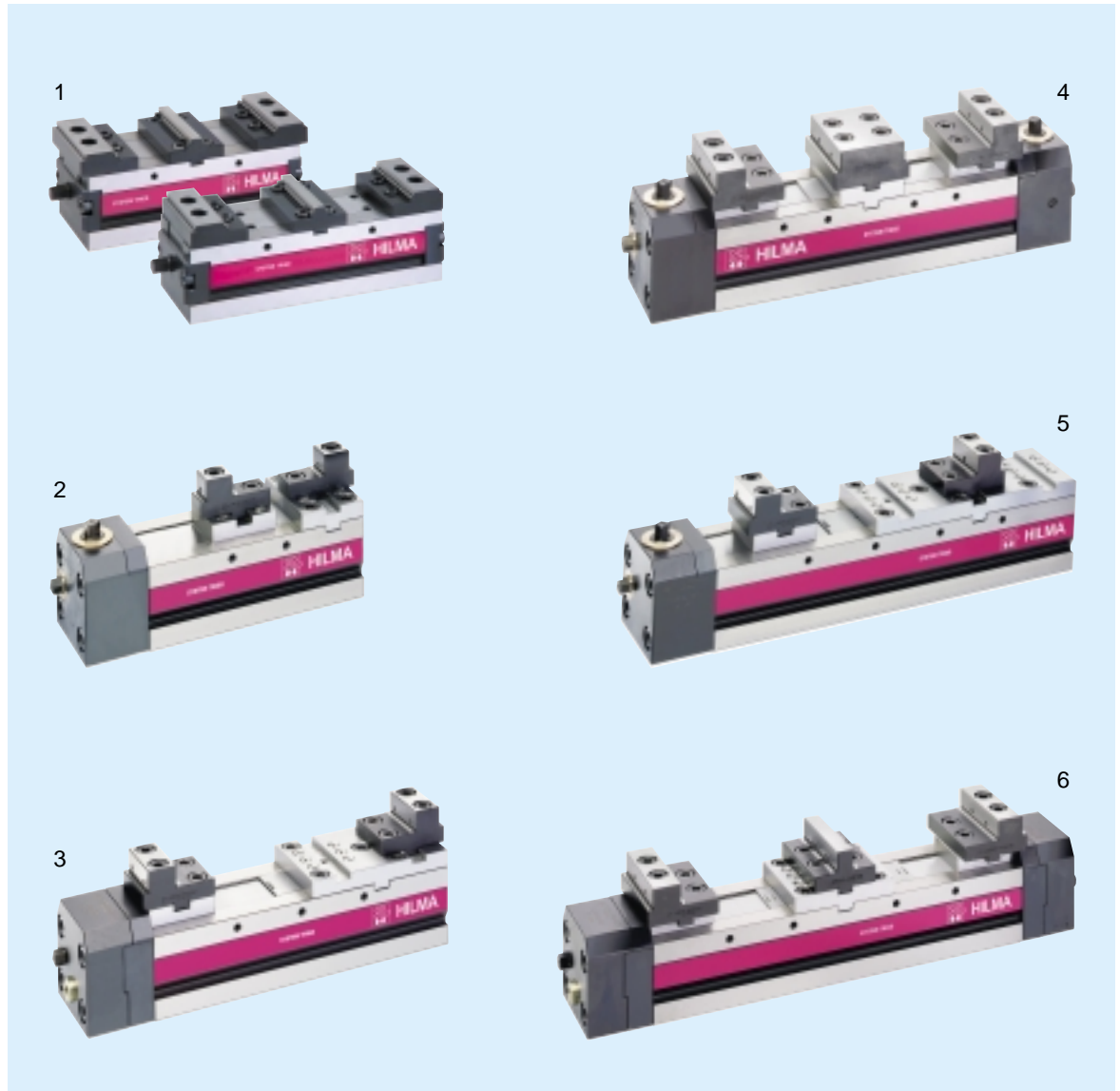

Optimum choice for any application:

1. Compact clamping system DUO 80, mechanical, overall lengths 200 and 240 mm
2. Compact clamping system CS 80 M, mechanical, with cam locking system, overall length 200 mm
3. Compact clamping system CS 80 H, hydraulic, overall length 280 mm
4. Compact double clamping system DCS 80 M, mechanical, with cam locking system, overall length 280 mm
5. Compact clamping system CS 80 M, mechanical, with cam locking system, overall length 360 mm
6. Compact double clamping system DCS 80 H, hydraulic, overall length 360 mm

The above illustrations show the various types of clamping jaws.

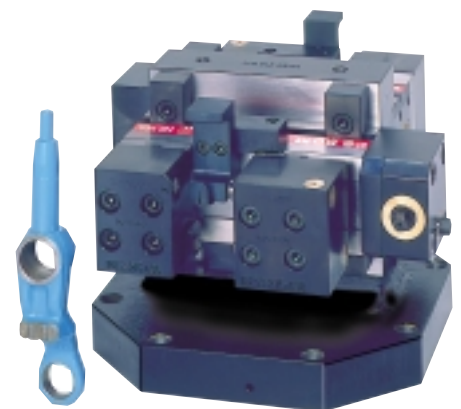

Where workpieces are frequently changed due to small batch sizes, the use of clamping systems with rapidly changeable jaw inserts is highly efficient.

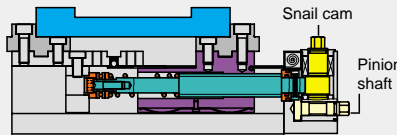
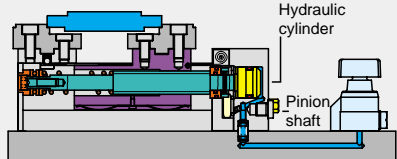
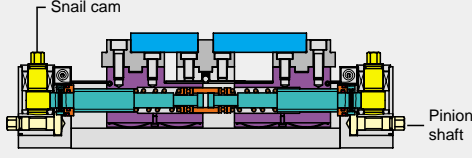
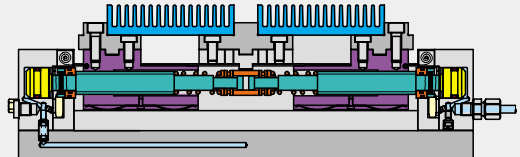

Compact clamping systems, summary and selection criteria

Type Part no.	Size mm	Type of system	Clamping width max.	Clamping force
DUO 80/200 9.3654.0601	200	 <p>Double clamping system, mechanical, with spindle drive</p>	2 x 72 mm	12 kN
DUO 80/240 9.3654.0701	240		2 x 94 mm	12 kN
CS 80 M/200 9.3614.0202	200	 <p>Single clamping system, mechanical, with cam locking system</p>	1 x 150 mm	20 kN
CS 80 M/280 9.3614.0302	280		1 x 230 mm	20 kN
CS 80 M/360 9.3614.0402	360		1 x 310 mm	20 kN
CS 80 H/200 9.3624.0202	200	 <p>Single clamping system, hydraulic, with spring return</p>	1 x 150 mm	20 kN
CS 80 H/280 9.3624.0302	280		1 x 230 mm	20 kN
CS 80 H/360 9.3624.0402	360		1 x 310 mm	20 kN
DCS 80 M/280 9.3634.0102	280	 <p>Double clamping system, mechanical, with cam locking system</p>	2 x 107 mm	20 kN
DCS 80 M/360 9.3634.0202	360		2 x 142 mm	20 kN
DCS 80 H/280 9.3644.0102	280	 <p>Double clamping system, hydraulic, with spring return</p>	2 x 107 mm	20 kN
DCS 80 H/360 9.3644.0202	360		2 x 142 mm	20 kN

Technical data Double clamping system DUO 80

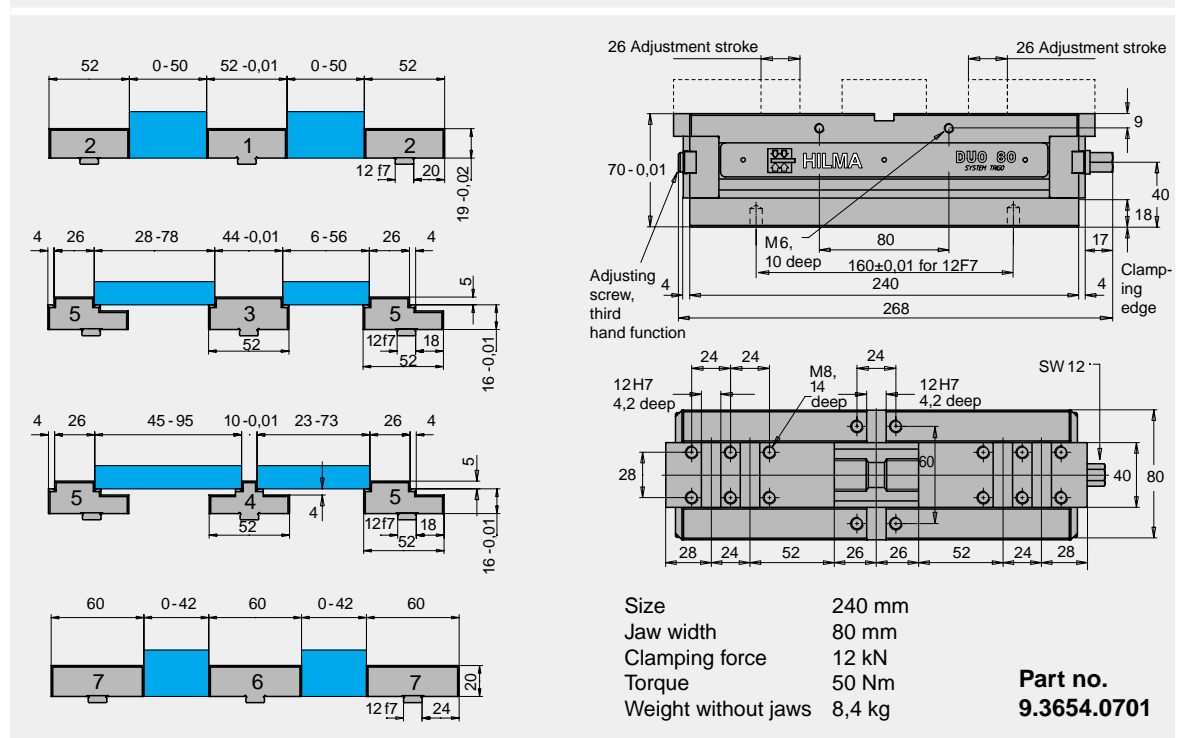
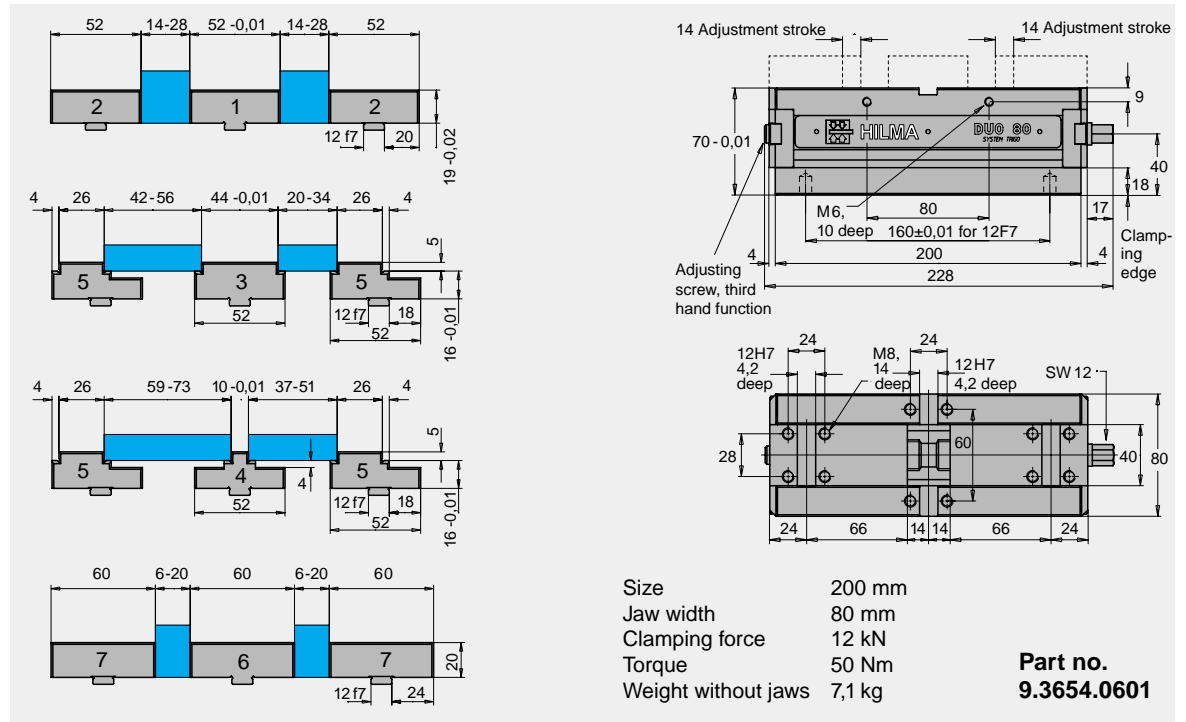

Standard clamping jaws, hardened and ground, including fastening screws

Item	Part no.	Designation	Item	Part no.	Designation
1	9.3913.4041	Central jaw 52 mm	5	9.3913.4111	Reversible step jaw
2	9.3913.4121	Reversible jaw	6	9.3913.4031	Central jaw, soft 60 mm
3	9.3913.4021	Central step jaw 44 mm	7	9.3913.4131	Reversible jaw, soft
4	9.3913.4011	Central step jaw 10 mm			



Technical data CS 80 M (mechanical) and CS 80 H (hydraulic)

Opening width using standard jaws. For more details, see pages 10/11

Size 200 mm

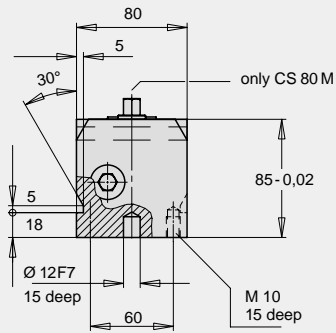
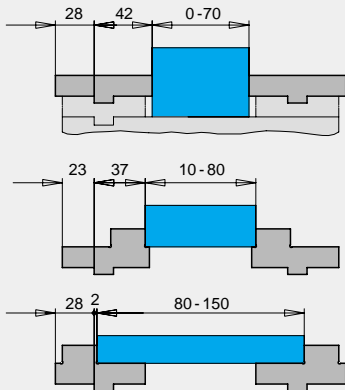

Clamping force	20 kN
Torque	60 Nm (M)
Operating pressure	250 bar (H)
Weight	9,7 kg

Size 280 mm

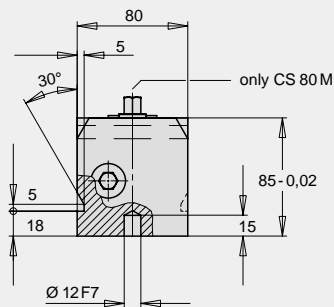
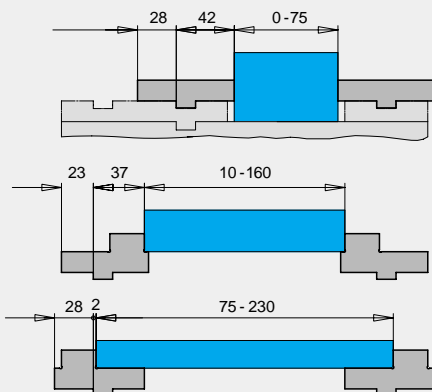

Clamping force	20 kN
Torque	60 Nm (M)
Operating pressure	250 bar (H)
Weight	12,7 kg

Size 360 mm

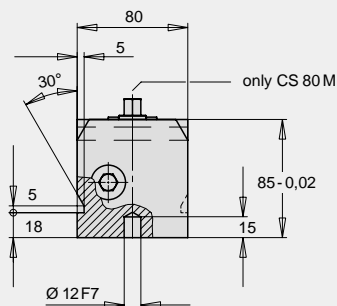
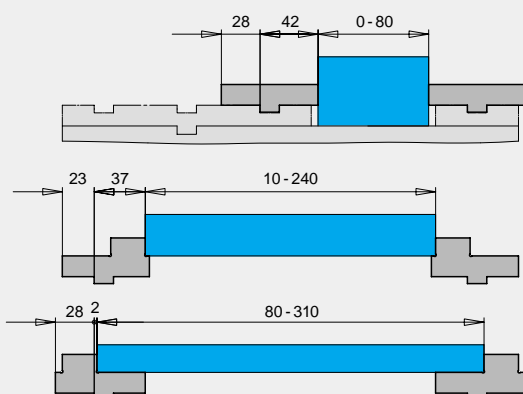

Clamping force	20 kN
Torque	60 Nm (M)
Operating pressure	250 bar (H)
Weight	15,7 kg

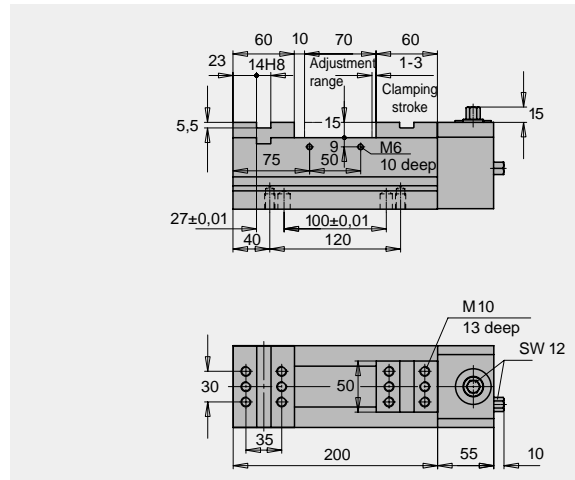
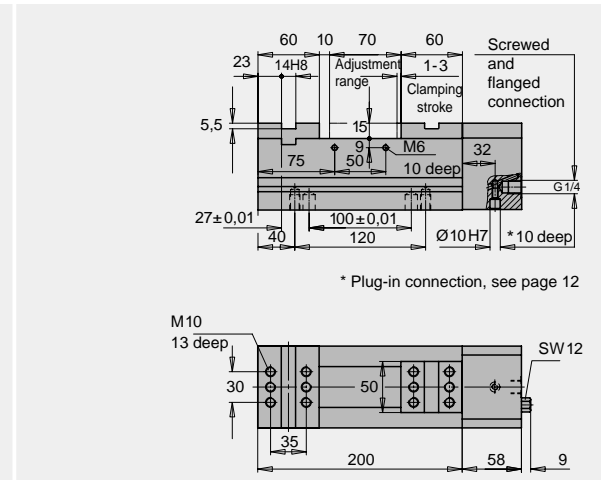
**Mechanical design, with power amplifier
CS 80 M**
**Hydraulic design
CS 80 H**

Part no. 9.3614.0202

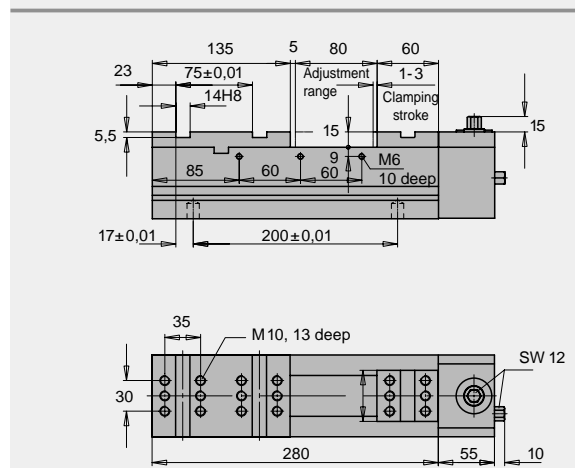
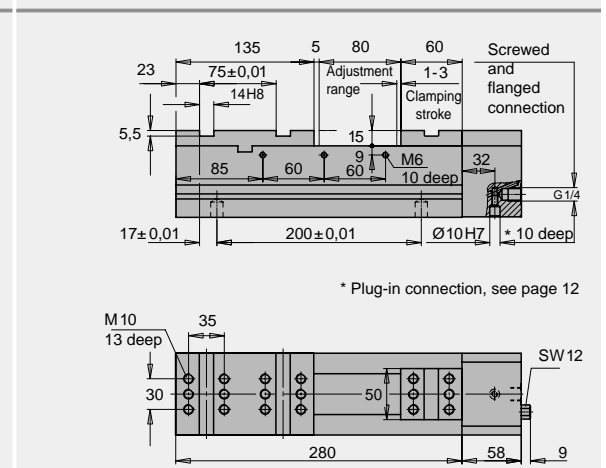
* Plug-in connection, see page 12

Part no. 9.3624.0202

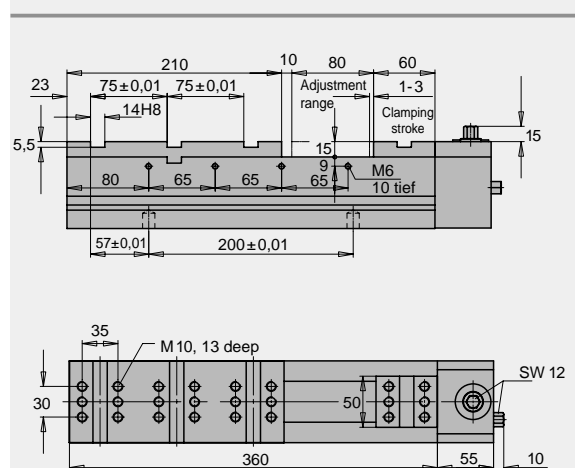
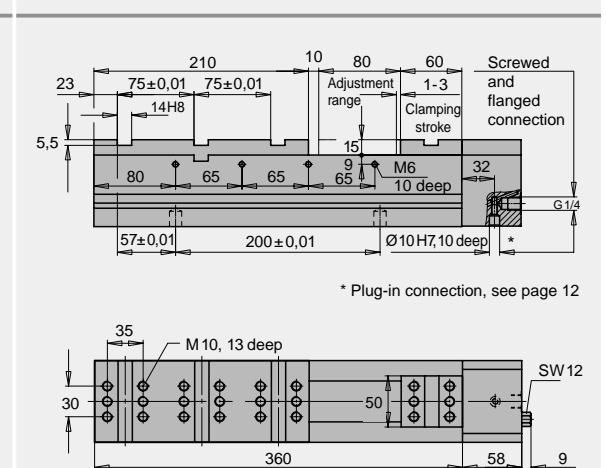
Part no. 9.3614.0302

* Plug-in connection, see page 12

Part no. 9.3624.0302

Part no. 9.3614.0402

* Plug-in connection, see page 12

Part no. 9.3624.0402

Technical data DCS 80 M (mechanical) and DCS 80 H (hydraulic)

Opening width using standard jaws. For more details, see pages 10/11

Size 280 mm

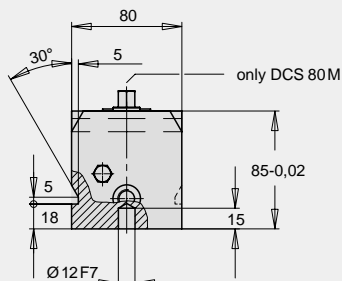
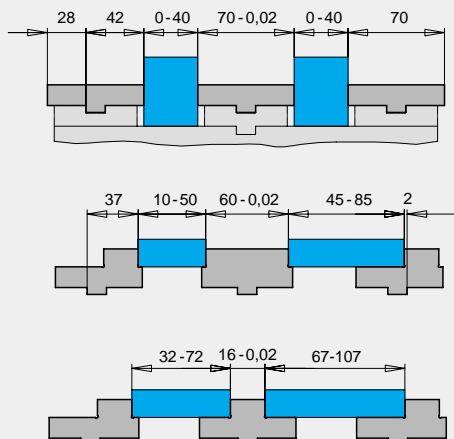

Clamping force	20 kN
Torque	60 Nm (M)
Operating pressure	250 bar (H)
Weight	14,5 kg

Size 360 mm

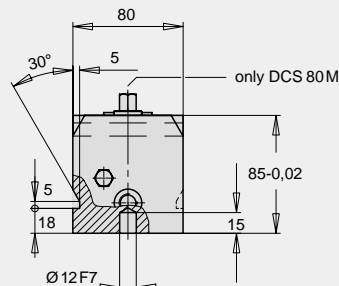
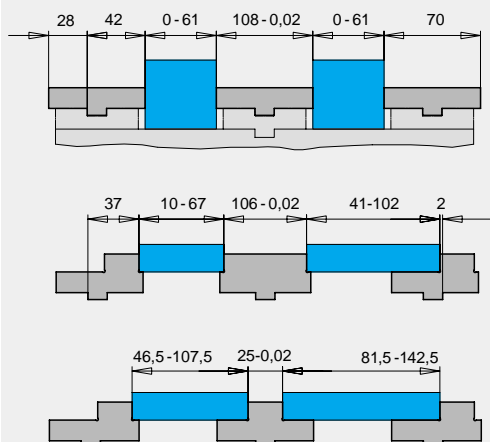

Clamping force	20 kN
Torque	60 Nm (M)
Operating pressure	250 bar (H)
Weight	18 kg

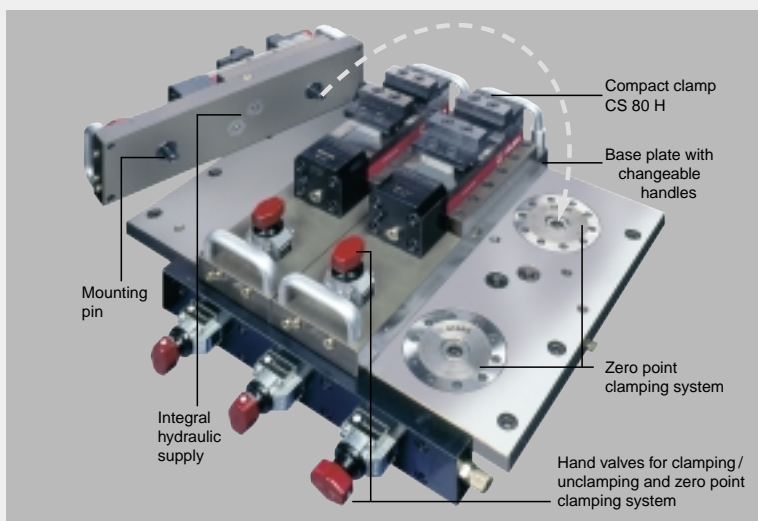

In order to reduce set-up times to a minimum, this hydraulic universal fixture has been provided with a zero point clamping system and with an integral hydraulic supply (screw-in coupling elements).

This ensures rapid and safe exchange of clamps of various types on the base plate.

The system is set up in a separate set-up area, alternating with other systems and in parallel with the machining cycle.

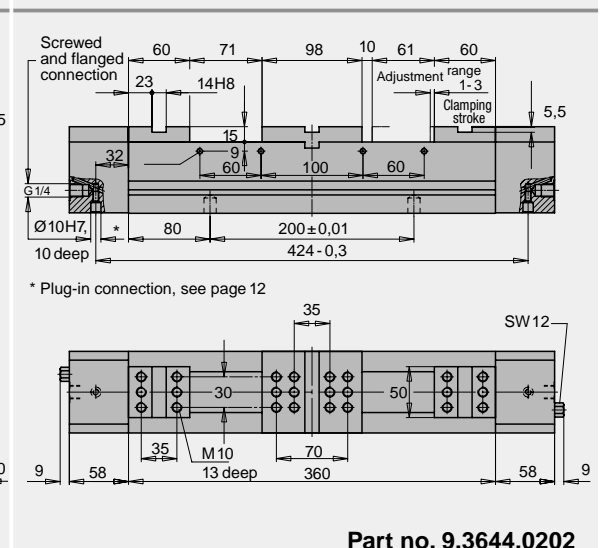
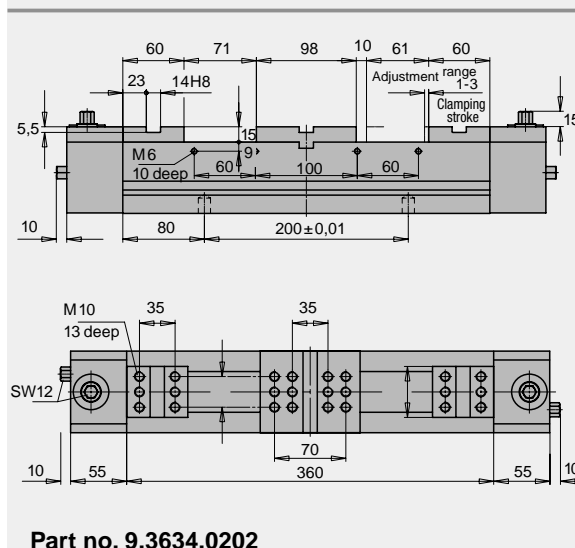
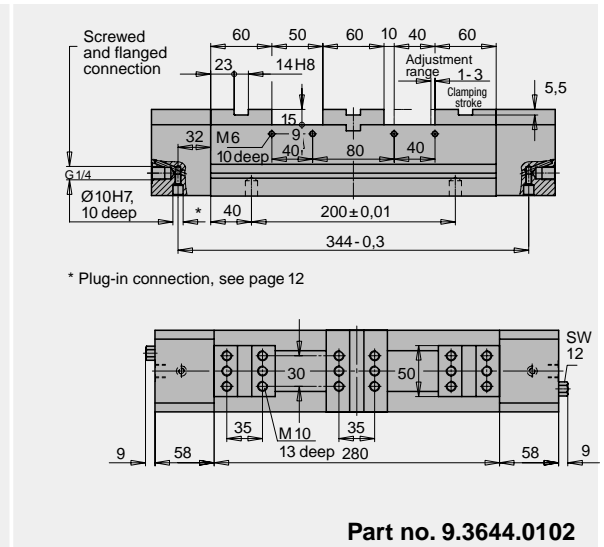
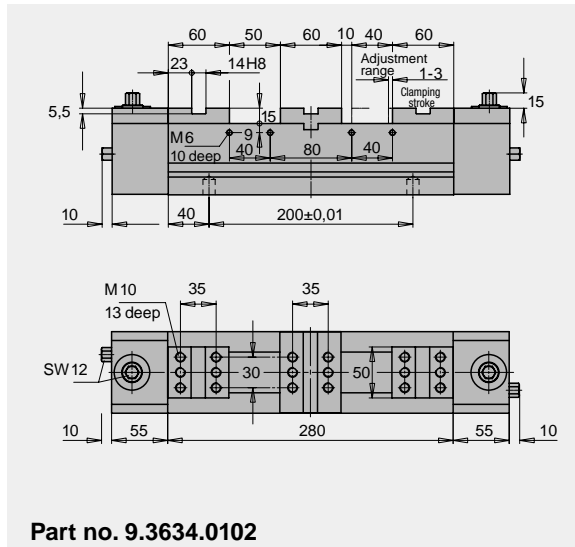
**Mechanical design, with power amplifier
DCS 80 M**
**Hydraulic design
DCS 80 H**

Reversible clamping system
with 4 compact clamps
CS 80 H.

The hydraulic oil is supplied
without pipework through
holes drilled in the base
plate. Clamping and un-
clamping is carried out
using hand valves.

The clamping force is adju-
stable and can be moni-
tored.

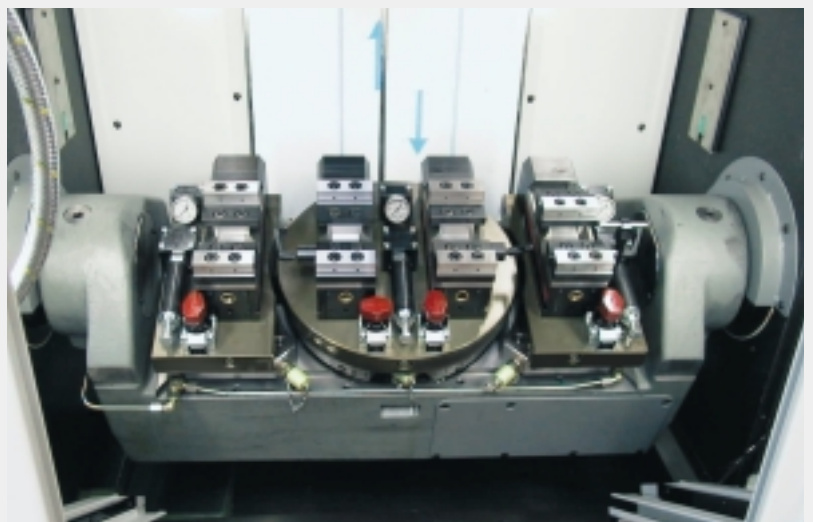

Interchangeable jaws for compact clamping systems

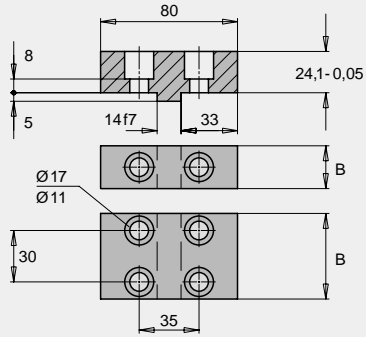

Reversible and central jaw soft 21 MnCr5G
for machining aluminium and non-ferrous metals and for adaptation to specific workpieces, including fastening screw

for all Compact clamping systems

Part no. 9.3911.4111, B = 25 mm
Part no. 9.3911.4121, B = 50 mm
Part no. 9.3911.4131, B = 80 mm

Examples of application:

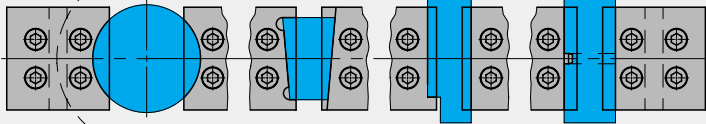
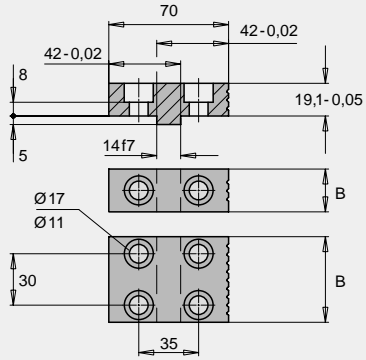



Reversible jaw
hardened and ground, clamping surfaces plain and serrated, respectively, including fastening screws

for all Compact clamping systems

Part no. 9.3911.4011, B = 25 mm
Part no. 9.3911.4021, B = 50 mm
Part no. 9.3911.4031, B = 80 mm

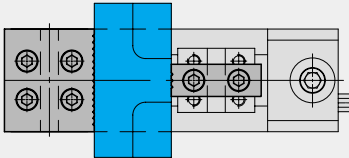
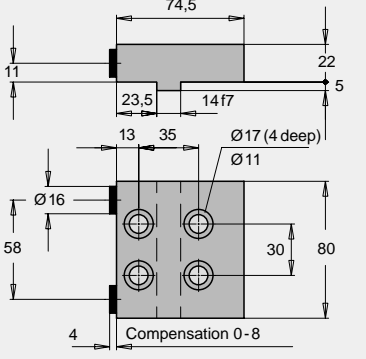
Examples of application:

Mechanical compensation jaw
Plain clamping bolt, including fastening screws, for all Compact clamping systems

Part no. 9.3911.4431

Sets of clamping bolts for compensation of between 0 and 32 mm

Part no. 9.3911.4461, Clamping bolt plain
Part no. 9.3911.4471, Clamping bolt serrated
Part no. 9.3911.4481, Clamping bolt with 90° cutting edge

Examples of application:

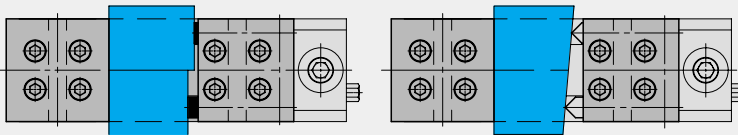
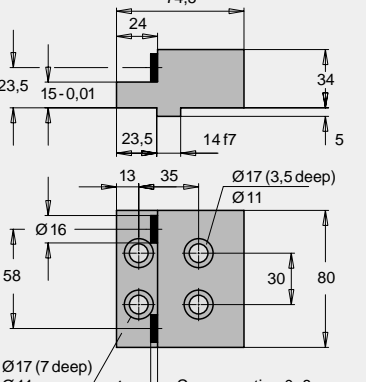
Mechanical compensation jaw, stepped
plain clamping bolt, including fastening screws, for all Compact clamping systems

Part no. 9.3911.4531

Sets of clamping bolts for compensation of between 0 and 32 mm

Part no. 9.3911.4561, Clamping bolt plain
Part no. 9.3911.4571, Clamping bolt serrated
Part no. 9.3911.4581, Clamping bolt with 90° cutting edge

Examples of application:

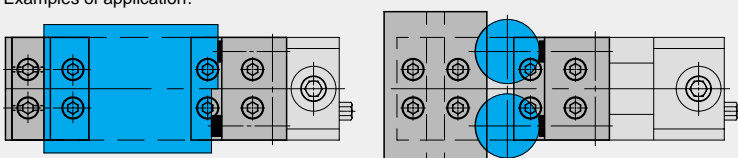



Interchangeable jaws for compact clamping systems

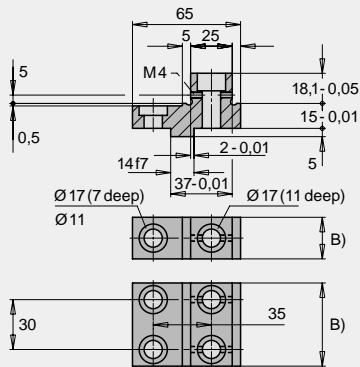

Reversible step jaw

hardened and ground, including fastening screws

for all Compact clamping systems

Part no. 9.3911.4211, B = 25 mm

Part no. 9.3911.4221, B = 50 mm

Part no. 9.3911.4231, B = 80 mm

Examples of application:

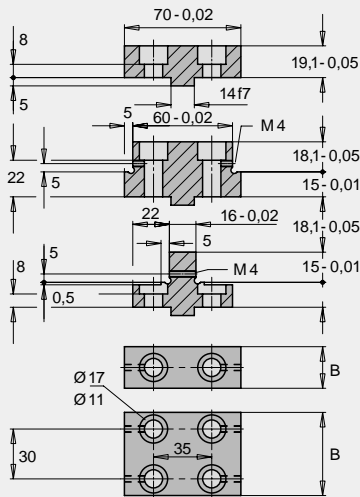
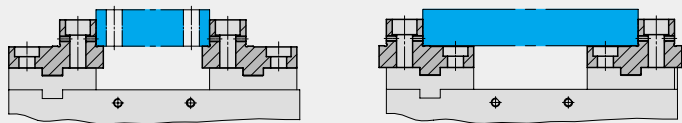

Central jaw

hardened and ground, including fastening screws

only for Compact clamping systems 9.3634.01/0202 and 9.3644.01/0202

Central jaw 70-0.02 mm

Part no. 9.3911.4771, B = 25 mm

Part no. 9.3911.4781, B = 50 mm

Part no. 9.3911.4791, B = 80 mm

Central jaw 60-0.02 mm

Part no. 9.3911.4741, B = 25 mm

Part no. 9.3911.4751, B = 50 mm

Part no. 9.3911.4761, B = 80 mm

Central jaw 16-0.02 mm

Part no. 9.3911.4711, B = 25 mm

Part no. 9.3911.4721, B = 50 mm

Part no. 9.3911.4731, B = 80 mm

Examples of application:

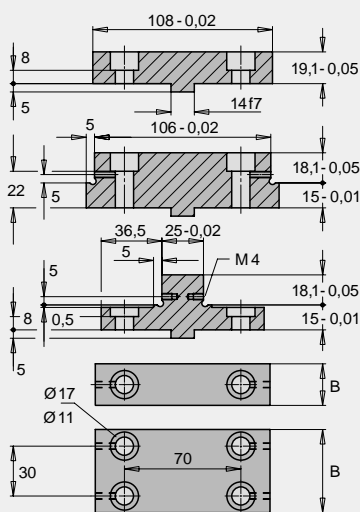
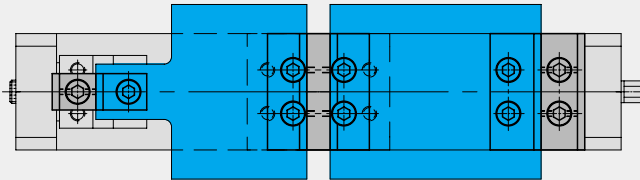

Central jaw

hardened and ground, including fastening screws

only for Compact clamping systems 9.3634.0202 and 9.3644.0202

Central jaw 108-0.02 mm

Part no. 9.3911.4671, B = 25 mm

Part no. 9.3911.4681, B = 50 mm

Part no. 9.3911.4691, B = 80 mm

Central jaw 106-0.02 mm

Part no. 9.3911.4641, B = 25 mm

Part no. 9.3911.4651, B = 50 mm

Part no. 9.3911.4661, B = 80 mm

Central jaw 25-0.02 mm

Part no. 9.3911.4611, B = 25 mm

Part no. 9.3911.4621, B = 50 mm

Part no. 9.3911.4631, B = 80 mm

Examples of application:

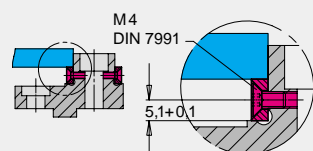
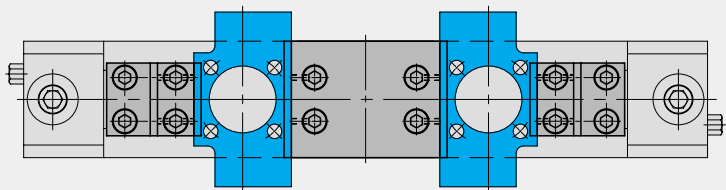

Fine steps

All stepped reversible jaws and central jaws are prepared for fitting fine steps or special workpiece pads as required by the customer.

When maintaining the dimension 5.1 + 0.1, the fine steps have a positive fit on their supports after having been screw-fastened.

Accessories for compact clamping systems

Ring spanner SW 12, 200 long

Part no.
9.3918.4311



Reversible ratchet 200 long with socket insert SW 12

Part no.
9.3918.4321



Torque wrench 10-50 Nm, SW 12

for mechanical Compact quick clamping systems

Part no. 9.3918.4011



Power units

for Compact clamping systems with hydraulic operation

Depending on their design, power units may be used for operating single clamping points, groups of clamping points or all clamping points together. Since our power units, which are delivered ready for connection, are based on a modular system, individual control versions are possible.



Set of positioning pins

consisting of a cylindrical and a milled positioning pin

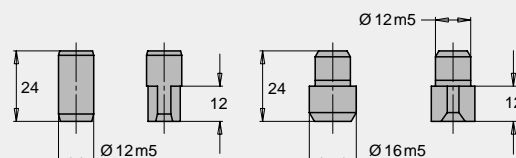

Part no. 9.3918.4211

Part no. 9.3918.4221

Key block

for positioning on machine beds and pallets provided with T-slots

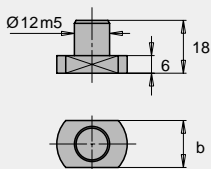

Part no.	Width b
5.0508.0089	14h6
5.0508.0091	18h6

Set of T-slot nuts (4 pieces)

for fastening to machine beds and pallets provided with T-slots

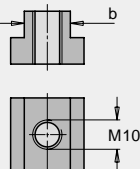

Part no.	Width b
9.3917.4221	14
9.3917.4241	18

Set of clamping claws and screws

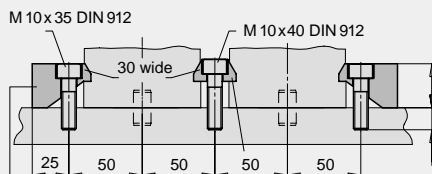

Part no. (4 pieces)
9.3917.4011

Part no. (2 pieces)
9.3917.4021

Set of clamping claws

consisting of 8 claws and screws, for fastening to clamping towers

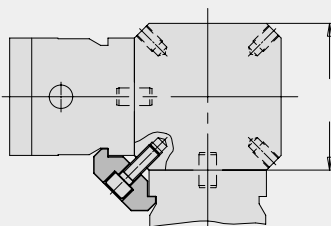

Part no.	a
9.3917.4041	100
9.3917.4051	120

Plug-in connector

For manifold mounting of Compact quick clamping systems with hydraulic operation.

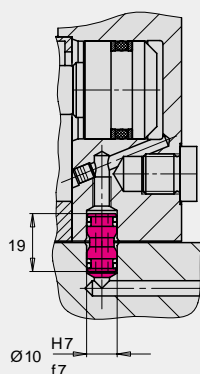

Part no.
8.0530.0023

Workpiece stop

for fastening to both sides of the basic element

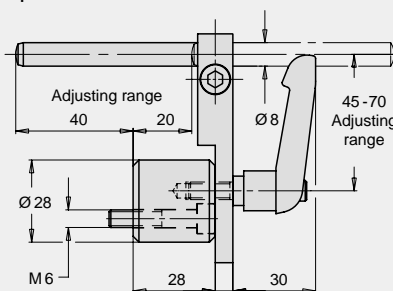

Part no.
9.3918.4111

Subject to change without notice. Printed in Germany