

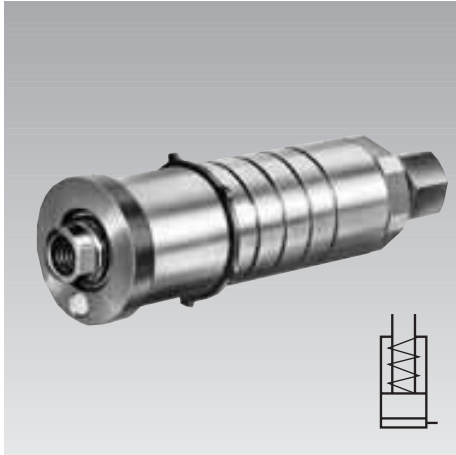

## Universal Clamping Cylinder

single acting with spring return  
max. operating pressure 200 / 500 bar



Type 1309-020

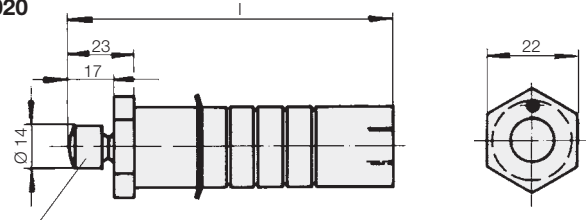

Contact bolt 3542-085 is included in our delivery

Type 1313-020, 1315-020, 1316-030, 1316-060

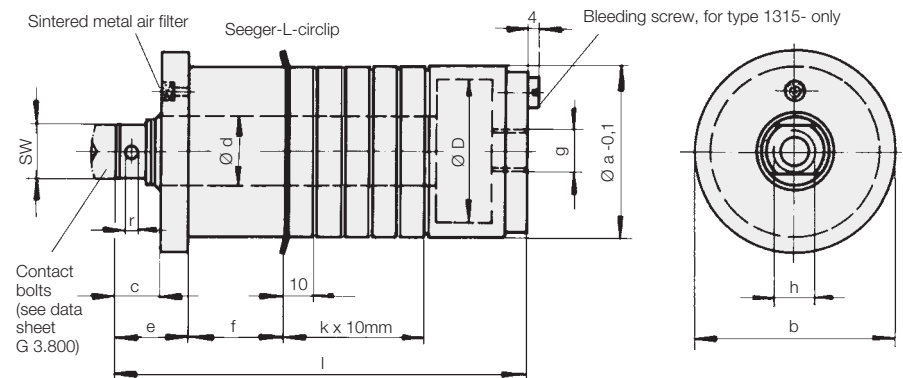

### Description

Universal clamping cylinders are particularly suited for clamping fixtures designed to hold various sizes of workpieces (parts families). They can be mounted directly into the fixture wall or installed into horizontal or vertical mounting brackets which are available as accessories. Spacers and C-washers provide axial adjustment in increments of 10 mm.

Bleeding of cylinders by opening the fitting connection, for type 1316- use bleeding screw provided.

### Material

Piston material: casehardening steel, hardened

Cylinder body: free cutting steel

### Important notes

Penetration of aggressive cutting lubricants and coolants through the sintered metal air filter into the cylinder's interior should be avoided by appropriate arrangement or covering.

If required, a vent hose has to be connected and be placed in a protected position.

Operating conditions, tolerances and other data see data sheet A 0.100.

Piston Ø D	[mm]	10	25	40	50	
Rod Ø d	[mm]	6	16	25	32	
Stroke ±1	[mm]	20	20	22	25	
Clamping force 100 bar	[kN]	0.7	4.9	12.6	19.5	1
at max. operating pressure	[kN]	3.7	24.5	62.8	39.0	3
Max. operating pressure	[bar]	500	500	500	200	2
Spring return force, min.	[N]	28	140	270	390	3
Oil volume per 10 mm stroke	[cm <sup>3</sup> ]	0.78	4.91	12.56	19.63	19
Ø a	[mm]	20	35	60	60	
b	[mm]	–	40	68	68	
c	[mm]	–	9	11	11	
e	[mm]	–	16	19	19	
f	[mm]	18.7	28.4	37.9	37.9	3
g		G 1/4	G 1/4	G 1/4	G 1/4	G
h x depth of thread	[mm]	–	M 10x15	M 16x25	M 20x30	M 20
k		4 x	5 x	5 x	5 x	1
l ±1	[mm]	111	123	138	139	
r	[mm]	–	–	4	4	
SW	[mm]	–	13	–	–	
Weight	[kg]	0.3	0.75	2.0	2.1	

Part-no.

1309-020 1313-020 1315-020 1316-030 1316-060

### Application example

