



# ROEMHELD

# B 1.5401

**Built-In Elements, piston and threaded bushing, complete with seals for block cylinder, double acting max. operating pressure 500 bar**



### Important notes

After tightening the threaded bushing it has to be secured against torsion, e.g. by means of a small threaded pin.

The tolerances for dimensions and surface roughness must not be exceeded.

Operating conditions, tolerances and other data see data sheet A 0.100.

Contact bolts see data sheet G 3.800

### Material

Piston: casehardening steel, hardened

Built-in bushing: free-cutting steel

### Seals

Max. cylinder temperature

Perbunan -25...+100°C

VITON® -20...+150°C

Alternatively, Perbunan or VITON® sealings can be delivered. VITON® seals are required for cylinder temperatures over 100°C and (or) fire-resistant liquids of type HSD.

### Application

Built-in elements are directly integrated in the fixture body. Such created cylinders can be used as push or pull cylinders.

Built-in elements are used on fixtures with narrow spaces, and for applications where mounted standard clamping elements limit the machining space or impede swarf flow.

### Description

The built-in elements consist of piston and threaded bushing. The piston is inserted into the location hole of the fixture. Then the built-in bushing is screwed into the fixture body. The bushing is let-in flush to the housing. Tightening of the threaded bushing is made with a pin-type face spanner.

Sealing with minimum leakage at the piston rod is obtained by two independent sealing steps. In addition, a wiper protects against contamination. Sealing in the fit hole is made by an O-ring/back-up ring combination.

### Range of force:

2 kN at piston Ø 16 mm and 100 bar up to 156 kN at piston Ø 63 mm and 500 bar  
3 standard stroke lengths are available.

Special versions are available on request. Please contact us.

### Advantages

- Space-saving installation of cylinders
- More compact fixtures
- More workpieces per fixture
- More machining space
- Less sensitive to swarf
- Sealing with very little leakage
- Individual adaptation possibilities

### Application example

The following example shows an injection mould with one built-in element. The built-in cylinder and wedge operate the profile slide to eject the break-outs and to clear the angle ribs.

### Advantage

Using built-in elements in the interior of the mould, direct control of motion cycles is possible without additional force deflection. Piping is not necessary, thus there will be very little chance of leakage.

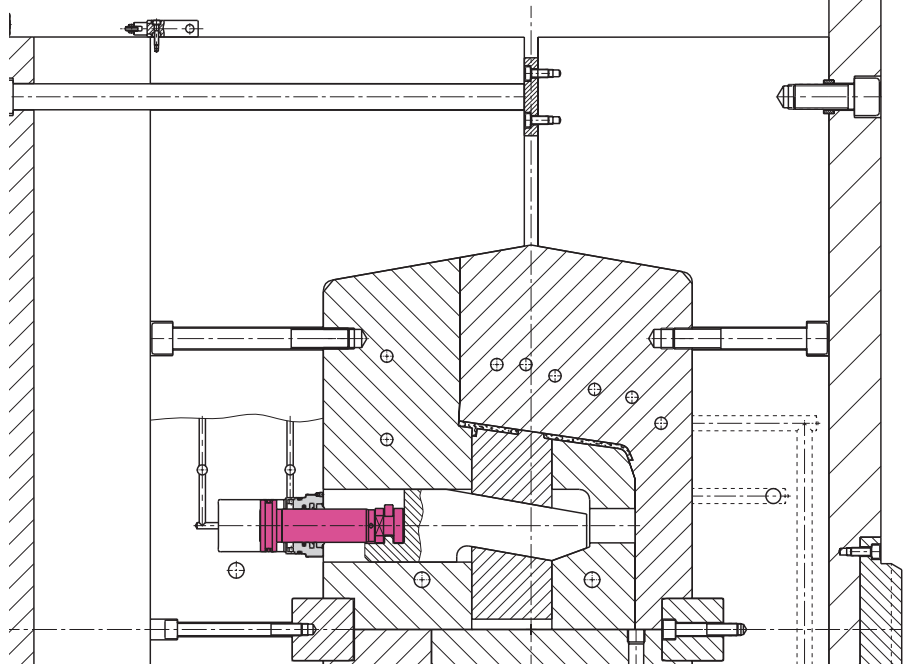

**Technical data  
and installation dimensions  
on request**



# ROEMHELD

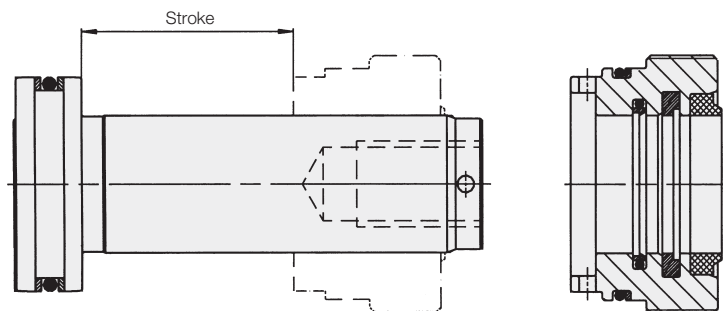

Technical data and installation dimensions  
on request

Piston and rod Ø	Stroke	Piston, complete		Threaded bushing, complete		Seal kit		
		Perbunan	VITON®	Perbunan	VITON®	Perbunan	VITON®	
16/10	16	<b>Part-no.</b>	<b>0350-110</b>	<b>0350-112</b>	<b>0154-110</b>	<b>0154-111</b>	<b>0131-151</b>	<b>0131-440</b>
	50	<b>Part-no.</b>	<b>0350-111</b>	<b>0350-113</b>				
25/16	20	<b>Part-no.</b>	<b>0350-114</b>	<b>0350-117</b>	<b>0154-310</b>	<b>0154-311</b>	<b>0131-154</b>	<b>0131-441</b>
	50	<b>Part-no.</b>	<b>0350-115</b>	<b>0350-118</b>				
	100	<b>Part-no.</b>	<b>0350-116</b>	<b>0350-119</b>				
32/20	25	<b>Part-no.</b>	<b>0350-120</b>	<b>0350-123</b>	<b>0154-410</b>	<b>0154-411</b>	<b>0131-156</b>	<b>0131-442</b>
	50	<b>Part-no.</b>	<b>0350-121</b>	<b>0350-005</b>				
	100	<b>Part-no.</b>	<b>0350-122</b>	<b>0350-006</b>				
40/25	25	<b>Part-no.</b>	<b>0350-124</b>	<b>0350-127</b>	<b>0154-510</b>	<b>0154-511</b>	<b>0131-158</b>	<b>0131-443</b>
	50	<b>Part-no.</b>	<b>0350-125</b>	<b>0350-128</b>				
	100	<b>Part-no.</b>	<b>0350-126</b>	<b>0350-129</b>				
50/32	25	<b>Part-no.</b>	<b>0350-130</b>	<b>0350-133</b>	<b>0154-610</b>	<b>0154-611</b>	<b>0131-160</b>	<b>0131-444</b>
	50	<b>Part-no.</b>	<b>0350-131</b>	<b>0350-134</b>				
	100	<b>Part-no.</b>	<b>0350-132</b>	<b>0350-135</b>				
63/40	30	<b>Part-no.</b>	<b>0350-136</b>	<b>0350-139</b>	<b>0154-710</b>	<b>0154-711</b>	<b>0131-166</b>	<b>0131-445</b>
	63	<b>Part-no.</b>	<b>0350-137</b>	<b>0350-140</b>				
	100	<b>Part-no.</b>	<b>0350-138</b>	<b>0350-141</b>				
80/50	32	<b>Part-no.</b>	<b>0350-142</b>	<b>0350-145</b>	<b>0154-810</b>	<b>0154-811</b>	<b>0131-167</b>	<b>0131-446</b>
	80	<b>Part-no.</b>	<b>0350-143</b>	<b>0350-146</b>				
	100	<b>Part-no.</b>	<b>0350-144</b>	<b>0350-147</b>				
100/63	40	<b>Part-no.</b>	<b>0350-148</b>	<b>0350-150</b>	<b>0154-910</b>	<b>0154-911</b>	<b>0131-168</b>	<b>0131-447</b>
	100	<b>Part-no.</b>	<b>0350-149</b>	<b>0350-151</b>				