

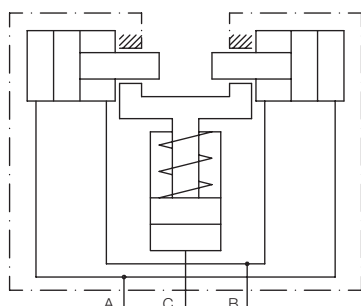

Position Flexible Clamp

double acting, separate locking port
max. operating pressure 250 bar

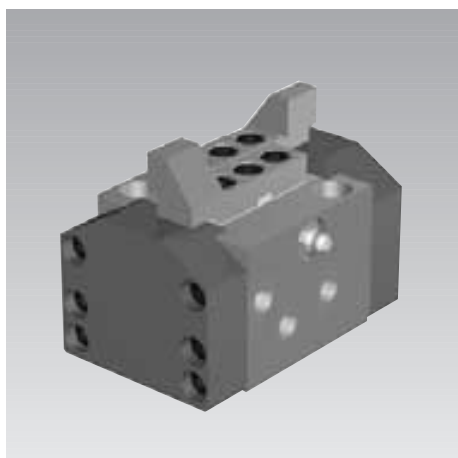

Position flexible clamping

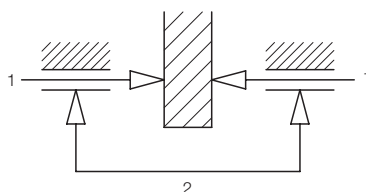

For machining in a clamping fixture in 3 levels, a workpiece will be positioned and clamped against a maximum of 5 support and location points.

If further sections of the workpiece have to be supported and clamped, additional work supports will be used, on top of which also clamping can be effected.

Problem: If the sections to be clamped are very unstable, already the contact of the support plunger causes deformation. If clamping will be made on these work supports, the caused deformation will not be calculable. Variations at the finish-machined workpiece will not be tolerable.

Solution: The use of position flexible clamping elements at such critical points can improve considerably the result.

If e.g. a small web has to be clamped, clamping jaws contact the workpiece from both sides with little force and position flexible. Condition is, that the web is within the clamping area. If the hydraulic pressure increases, the clamping force is built up uniformly and nipper-like at both sides, so that there will not be a displacement or deformation from the pre-determined position.

This is the so-called "floating" clamping, since both oppositely-arranged pistons would "float" in case of a workpiece displacement parallel to the piston axis.

After pressurising the separate locking port, the jaws are locked and are thereby in the position to compensate machining forces in all directions.

Advantages

- Compact 2-jaws clamping element
- For exterior and interior clamping
- Clamping jaws easily adaptable
- Position flexible within the clamping range
- Can be adapted to big workpiece tolerances
- Very low displacement forces act on the workpiece
- Compensation of machining forces from all directions
- Double-acting clamping function
- Locking port can be controlled separately
- Mounting from 4 sides possible
- Oil supply alternatively via fittings or drilled channels
- Clamping slide can be greased

Installation and connecting possibilities

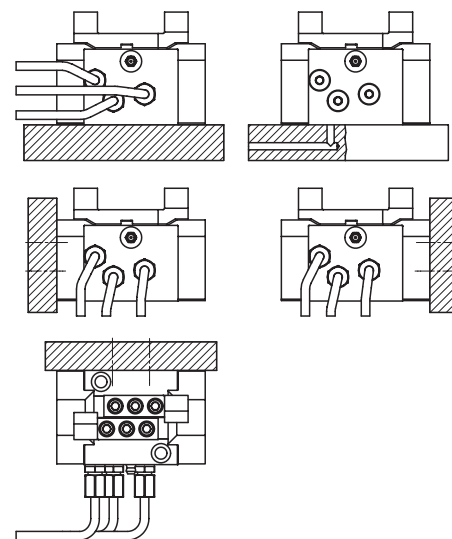

Description

The position flexible clamp is a small vice with two movable jaws, which are operated by a common hydraulic port. Independently of its position within the clamping area, the workpiece will be clamped nipper-like (floating).

By means of a separate locking port, both jaws are hydraulically locked. The clamped workpiece can no longer "float", if the machining forces are introduced. Oil supply to the locking port can be controlled by a sequence valve.

Application

Position flexible clamping elements can be used for supporting and clamping of unstable workpiece sections. They adapt themselves to the position of the clamping point without deforming them. They cushion vibrations and compensate machining forces from all directions.

Important notes

The upper face of the locking piston clamping element has to be checked from time to time with regard to contamination by swarf and cleaned, if required.

Operating conditions, tolerances and other data see data sheet A 0.100.

Application example

The figure shows a position flexible clamp for "floating clamping" of a self-supporting arm of a power unit support of the automotive industry, which has been fixed in its position by means of swing clamps as per data sheet B 1.880 and B 1.891.

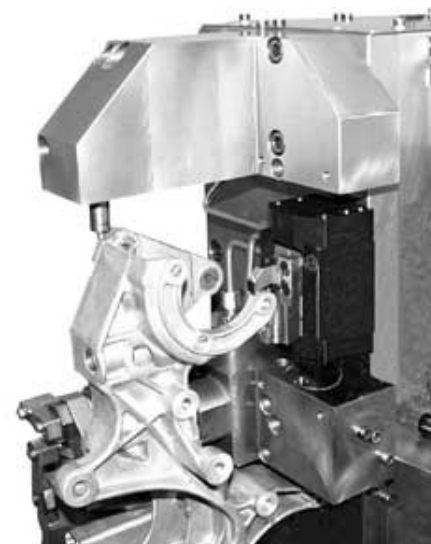



ROEMHELD

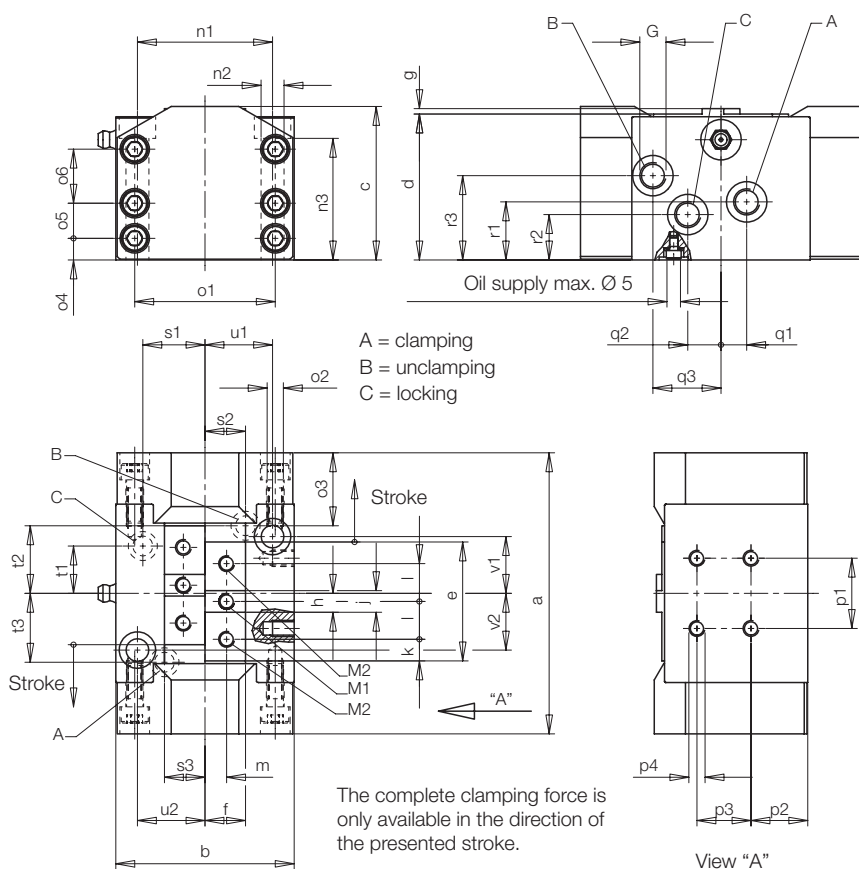

The position flexible clamping element, can be fixed alternatively at the bottom (dimensions n1 up to n3, v1/v2, u1/u2), or at the back (dimensions p1 up to p4).

It can also be fixed at both sides. For this purpose per screw row with gauge for bore holes n1 two of the three available screws have to be removed and replaced by the fixing screws (dimensions o1 up to o6). These will hold the complete piston pressure and have to be screwed in at least to dimension o3 - 1 (2) mm.

For manifold mounting remove socket head cap screws with USIT rings and screw-in plugs G 1/8 in the body

O-rings and plugs see accessories.

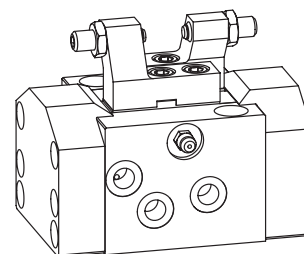

Clamping force at 250 bar	[kN]	7
Holding force at 250 bar	[kN]	4
Stroke, per clamping jaw	[mm]	6
Oil volume clamping	[cm ³]	1.9
Oil volume unclamping	[cm ³]	0.7
Oil volume locking	[cm ³]	5.4
a	[mm]	104
b	[mm]	66
c	[mm]	56.8
d	[mm]	54
e	[mm]	44
f	[mm]	15
G		G 1/8
g	[mm]	2
h	[mm]	7
j	[mm]	8 f7
k	[mm]	8
l	[mm]	14
M1 / M2 x depth of thread	[mm]	M 6x12 / M 6x10
m	[mm]	8
n1 / n2 / n3	[mm]	50 / Ø 8,5 / 45
o1 / o2 / o3 (Δ max. screw-in depth)	[mm]	52 / M6 / 27
o4 / o5 / o6	[mm]	8 / 13 / 20
p1 / p2 / p3 / p4 x depth of thread	[mm]	26 / 21 / 20 / M 6x8
q1 / q2 / q3	[mm]	9.5 / 12.3 / 25.2
r1 / r2 / r3	[mm]	21.5 / 16.8 / 31.2
s1 / s2 / s3	[mm]	23 / 15 / 15
t1 / t2 / t3	[mm]	17.5 / 25 / 25.5
u1 / u2	[mm]	25 / 25
v1 / v2	[mm]	21 / 21
Part-no.		4412-974

Accessories

Plug G 1/8	(3 x required)
O-ring 8x1.5	(3 x required)

Part-no.

3610-047
3000-275

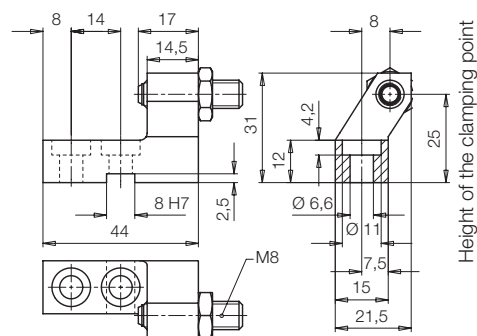

Clamping jaw for exterior clamping of a work-piece web with a thickness of 6 up to 14 mm (adjustable from 0 up to 18 mm).

Please consider for your own design of the clamping jaws, that a maximum height of the clamping point of 31 mm must not be exceeded.

Clamping jaw with swivel contact bolt

Part-no. 3548-447