

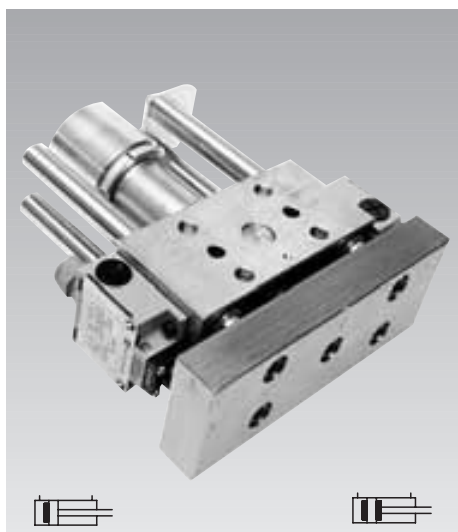

RS Hydraulic Slide

double acting, with 4 guide rods, max. operating pressure 250 bar



Areas of application

- Deburring tools
- Tool manufacture
- Metal forming
- Mould making
- Presses
- Punching presses
- Power workholding
- Assembly technics

Description

The RS hydraulic slide is a compact hydraulic block cylinder with 4 laterally-mounted guide rods for compensation of high transverse and moment forces.

A front block is mounted at the guide rods and the piston rod. Deburring, pressing and punching tools (working loads) or other mounting parts can be fixed at this block.

Large force range

0.5 kN at piston-Ø 25 mm and 10 bar up to 196 kN at piston-Ø 100 mm and 250 bar. Additional moment forces by transverse force and working loads: see page 4 and 5.

Materials / corrosion protection

Piston and guide rods are ground and consist of high-tensile steel materials.

The guide rods of the RS hydraulic slide are chromium-plated. All other components are galvanised for protection against corrosion.

The front block is manufactured from St37k. This component is not protected against corrosion.

Advantages

- **Two series are available:**
 - **Standard version RSS:**
7 sizes with 7 stroke lengths
 - **Reinforced version RSV:**
4 sizes with 7 stroke lengths
- **Reinforced version**
The reinforced version RSV is suitable for higher loads due to larger distances and diameters of the guide rods.
- **Two hydraulic connecting possibilities**
The RS hydraulic slide can optionally be supplied with hydraulic oil from above or from below by means of a connection for manifold mounting.
- **Two fixing possibilities**
Mounting can be made by cross holes from above or from below, using the internal threads at the bottom.
- **Stroke end cushioning**
Cushioning at the rear (piston side) is standard. Cushioning at the front (piston rod side) is optionally available. The stroke end cushioning protects the slide against damage in the case of high loads. Additional mounting of stops and cushioning elements is not required.
- **Force compensation by dowel holes or tenon slot**
All axial forces can be compensated by the dowel holes at the bottom or the tenon slot. Additional support is not required.
- **Fluids**
The RS hydraulic slide can be operated by hydraulic oil as well as by fire-resistant liquids (e.g. water glycol HFC).
- **Option: limit switches**
For monitoring of the stroke ends, the RS hydraulic slide can be equipped with two potential-free mechanical limit switches.
- **Option: front block**
Optionally, a front block can be supplied, which can be provided with fixing holes by the customer.
- **Option: sealing material**
The standard sealing material is Perbunan, suitable for temperatures up to 100°C. For temperatures up to 180°C, all versions can be supplied with VITON® seals with PTFE guide bands.
- **Special versions as per customer's specification can be supplied**
Please contact us.

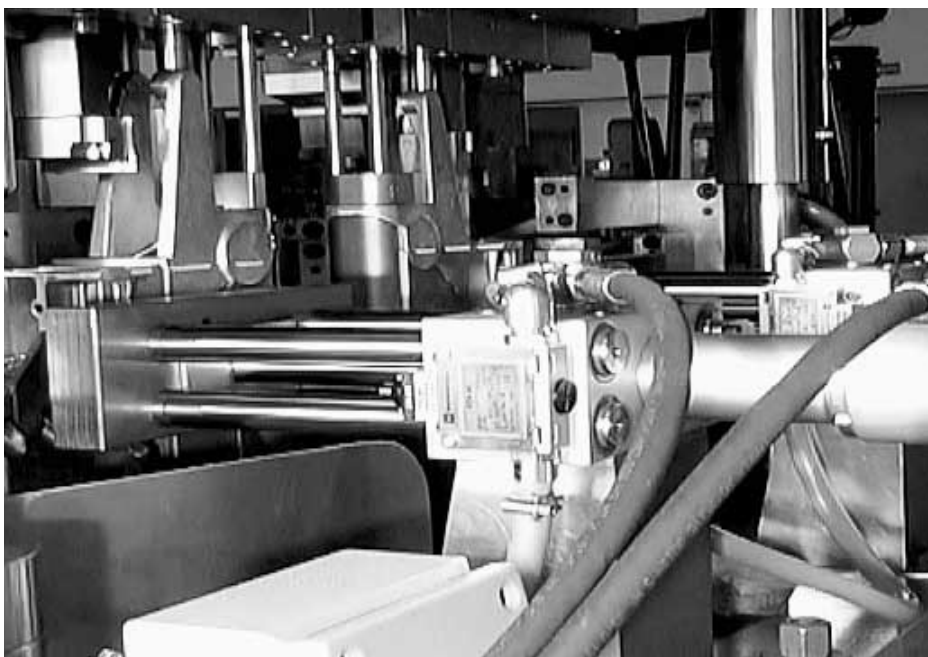

Application of the RS hydraulic slide on a deburring tool





Sizes / strokes

Sizes		Piston Ø	Piston rod Ø
Standard RSS	Reinforced RSV	[mm]	[mm]
RSS3	-	25	16
RSS4	-	32	20
RSS5	-	40	25
RSS6	RSV6	50	32
RSS7	RSV7	63	40
RSS8	RSV8	80	50
RSS9	RSV9	100	60

All sizes can be supplied with the stroke lengths **50/75/100/125/150/175/200 mm**. Special strokes are available on request.

Operating pressure

Max. operating pressure: 250 bar

Piston speed

Maximum piston speed v_{max} : 0.5 m/s

The flow rates Q as a function of the piston speed v are shown in the diagram on page 6.

Mounting position

Any

Operating temperature

Perbunan seals: -30 up to +100°C

VITON®-seals

with PTFE guide band: -20 up to +180°C

Seals/guide band

The RS hydraulic slide can optionally be supplied with Perbunan or VITON® seals. For the version VITON® with PTFE guide band, the admissible moments have to be reduced due to the guide band.

Tolerances

All tolerances which are not indicated correspond to DIN ISO 2768 m.

The tolerance for strokes is ± 1 mm (at the front ± 0.2 mm, at the rear ± 0.8 mm)

Fluids

All hydraulic oils of types HL and HLP as per DIN 51 524 in the viscosity ranges from 9 to 100 mm²/s can be used. The maximum admissible oil temperature is 80°C. For continuous operation and high loads hydraulic oils HLP are generally to be used.

The RS hydraulic slide is also suitable for operation with fire-resistant liquids.

> HFC (water glycol): with Perbunan or VITON® seals

> HFD: only with VITON® seals

Hydraulic connections

The RS can be connected at the top or at the bottom.

– Ports at the top:

Extend and retract: Whitworth connecting thread as per DIN-ISO 228-1

– Ports at the bottom

Retract: Manifold mounting connection with O-ring seals (the O-ring is supplied with the element)

Extend: Whitworth connecting thread as per DIN-ISO 228-1

Due to assembly reasons the type of connection has to be indicated when placing an order.

Guides

All seals and guide elements are protected against penetrating dirt and dust by wipers. In the case of adherent impurities or sediments as e.g. adhesives and welding spatter separate covers or other devices for protection are to be mounted. The guides consist of high-tensile steel bushings with a Teflon sliding coating and do not require additional lubrication or maintenance.

Installation

Due to its block design, the RS can be mounted and dismantled in no time. The dowel holes and the tenon slot provided at the bottom side of the slide facilitate an exact alignment and a safe fixing also for extreme loads.

Limit switches

For monitoring of the stroke ends, the RS hydraulic slide can be equipped with two potential-free mechanical limit switches. These are mounted at the side of the body.

Operation of the limit switch for the stroke end at the rear is made by the guide plate. Operation of the limit switch for the stroke end at the front is made by means of a control vane which is fixed at two guide rods. The control vane is generally supplied with the element, also if the order will be placed without limit switches.

Limit switches and control vane can be fixed at both sides of the RS, since corresponding threads are provided in the body and the guide rods.

Technical data – limit switches

Manufacturer: Telemecanique

Type: XCK-M110

Switch: Break and make contact with jump function

Operating data: ~AC-15; A300 (U_e=240V, I_e=3A) = DC-13; Q300 (U_e=250V, I_e=0,27A) as per IEC 947-5-1 appendix A

Environmental

temperature: -25 up to +70°C

Code class: IP66 as per IEC 529, IP665 as per NF C 20-010

Protection against accidental contact:

Class I as per IEC 536 and as per NF C 20-010

Connection: Terminal screws, min. 1 x 0,34 mm², max. 2 x 2,5 mm²

Cable connection:

3 threads at the side for screwed cable gland Pg11 (2 threads are provided with plugs)

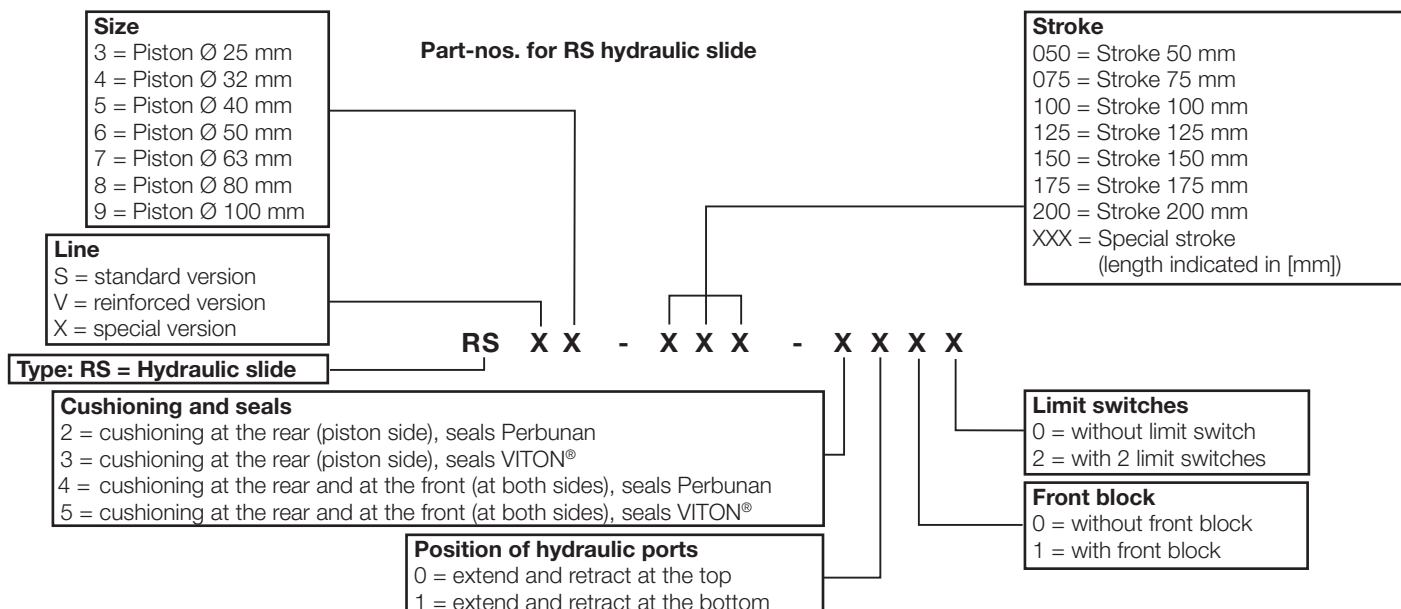

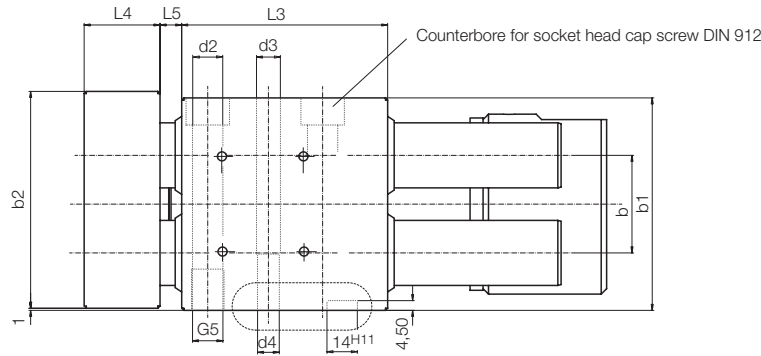
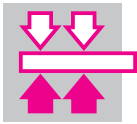

Connecting dimension for connection at the bottom

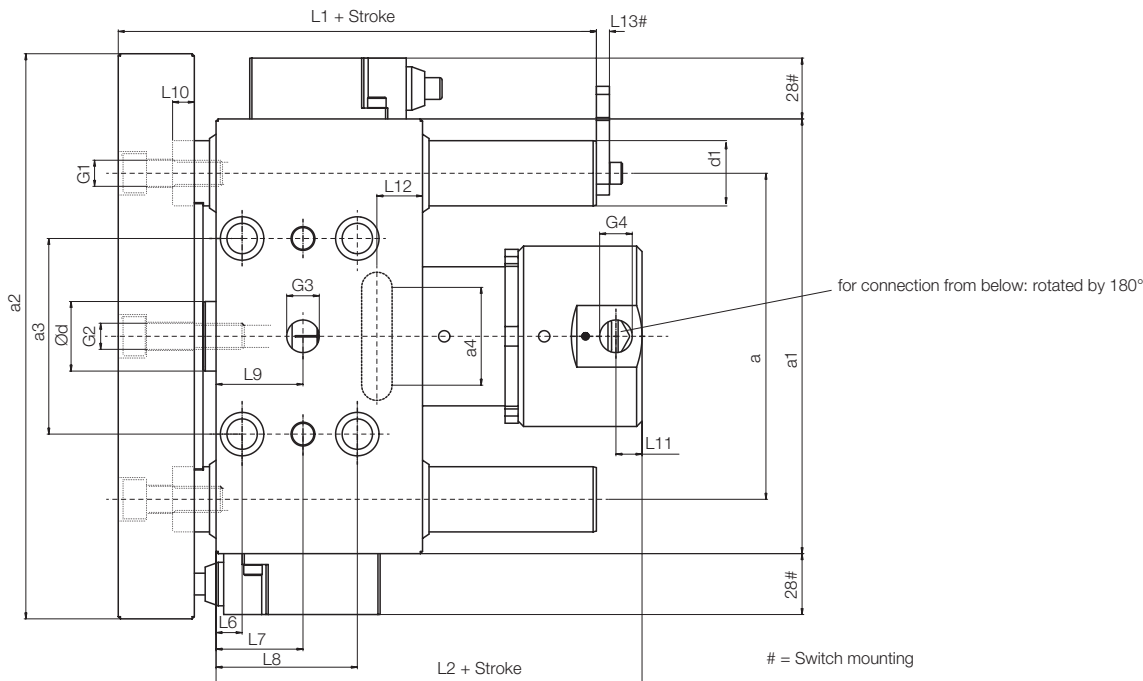
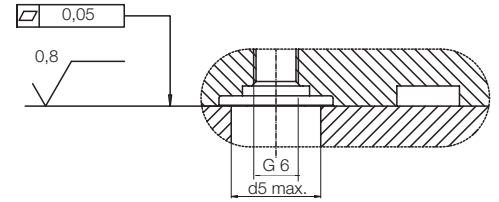

Dimensions – Standard version RSS

Size	Piston Ø	Piston rod Ø d	Standard strokes	L1 + stroke	L2* + stroke	L3	L4	L5	L6	L7	L8	L9	L10	L11
RSS3	25	16	50/75/100/125/150/175/200	117	approx. 97	65	30	approx. 7	10	32	55	29	10	10
RSS4	32	20	50/75/100/125/150/175/200	120	approx. 102	75	30	approx. 10	12	35	60	32	10	12
RSS5	40	25	50/75/100/125/150/175/200	125	approx. 100	80	30	approx. 10	12	40	68	31	10	12
RSS6	50	32	50/75/100/125/150/175/200	145	approx. 106	95	35	approx. 10	12	40	65	40	10	12
RSS7	63	40	50/75/100/125/150/175/200	159	approx. 144	100	40	approx. 11	17	46	75	39	12	18
RSS8	80	50	50/75/100/125/150/175/200	159	approx. 155	100	40	approx. 11	17	46	75	46	12	20
RSS9	100	60	50/75/100/125/150/175/200	179	approx. 162	119	40	approx. 11	20	55	90	54	12	23

* For stroke = 50: L2 + 75

Size	L12	L13	a	a1	a2	a3	a4	b	b1	b2	d1 Ø	d2 Ø	d3 Ø	d4H7 Ø	d5 Ø	G1	G2	G3	G4	G5	G6
RSS3	11	6	95	130	190	65	29	35	64	70	16	9	9	8	20	M10	M10	G1/4	G1/4	M10	M10x1
RSS4	15	6	110	150	210	65	29	40	74	80	20	11	11	10	20	M10	M10	G3/8	G3/8	M12	M10x1
RSS5	18	6	125	170	230	80	29	43	84	90	25	11	11	10	20	M12	M12	G3/8	G3/8	M12	M10x1
RSS6	21	6	150	200	260	90	45	45	98	100	30	14	11	10	20	M12	M12	G3/8	G3/8	M16	M10x1
RSS7	21	6	175	225	285	120	60	54	124	125	30	14	11	10	30	M16	M16	G1/2	G1/2	M16	M16x1,5
RSS8	18	6	200	260	320	134	90	54	124	125	40	17,5	13	12	30	M16	M20	G1/2	G1/2	M20	M16x1,5
RSS9	24	6	220	280	340	153	110	90	158	160	40	17,5	13	12	30	M20	M24	G1/2	G1/2	M20	M16x1,5

Dimensions in mm



Dimensions – Reinforced version RSV

Bauggröße	Piston Ø	Piston rod Ø d	Standard strokes	L1 stroke	L2*	L3	L4	L5	L6	L7	L8	L9	L10	L11
RSV6	50	32	50/75/100/125/150/175/200	145	approx.106	95	35	approx.10	12	40	65	40	10	12
RSV7	63	40	50/75/100/125/150/175/200	159	approx.144	100	40	approx.11	17	46	75	39	12	18
RSV8	80	50	50/75/100/125/150/175/200	159	approx.155	100	40	approx.11	17	46	75	46	12	20
RSV9	100	60	50/75/100/125/150/175/200	179	approx.162	119	40	approx.11	20	55	90	54	12	23*

* For stroke = 50: L2 +75

Size	L12	L13	a	a1	a2	a3	a4	b	b1	b2	d1 Ø	d2 Ø	d3 Ø	d4H7 Ø	d4 Ø	G1	G2	G3	G4	G5	G6
RSV6	21	6	260	340	400	200	80	55	118	120	35	14	11	10	20	M12	M12	G3/8	G3/8	M16	M10x1
RSV7	21	6	260	340	400	200	100	60	128	130	35	14	11	10	30	M16	M16	G1/2	G1/2	M16	M16x1.5
RSV8	18	6	285	360	420	210	150	70	148	150	45	17.5	13	12	30	M16	M20	G1/2	G1/2	M20	M16x1.5
RSV9	24	6	320	400	460	230	180	70	158	160	50	17.5	13	12	30	M20	M24	G1/2	G1/2	M20	M16x1.5

Dimensions in mm

Piston force and oil volume per 100 mm stroke

The piston forces of the standard version RSS and the reinforced version RSV are identical.

Size	RS.3	RS.4	RS.5	RS.6	RS.7	RS.8	RS.9
Piston Ø [mm]	25	32	40	50	63	80	100
Piston rod Ø [mm]	16	20	25	32	40	50	60
Piston area [cm ²]	4.91	8.04	12.6	19.6	31.2	50.3	78.5
Annulus area [cm ²]	2.90	4.90	7.66	11.6	18.6	30.6	50.3

Force data in kN at an operating pressure in bar

10 bar	Push force [kN]	0.49	0.80	1.26	1.96	3.12	5.03	7.85
	Pull force [kN]	0.29	0.49	0.77	1.16	1.86	3.06	5.03
100 bar	Push force [kN]	4.91	8.04	12.6	19.6	31.2	50.3	78.5
	Pull force [kN]	2.90	4.90	7.66	11.6	18.6	30.6	50.3
250 bar	Push force [kN]	12.3	20.1	31.4	49.1	77.9	125.7	196.4
	Pull force [kN]	72.4	12.3	19.1	29.0	46.5	76.6	125.7
Required oil per 10 mm stroke	Stroke to extend [cm ³]	4.91	8.04	12.6	19.6	31.2	50.3	78.5
	Stroke to retract [cm ³]	2.90	4.90	7.66	11.6	18.6	30.6	50.3

The maximum working load at the front block in kg

The maximum working loads of the standard version RSS and the reinforced version RSV are identical. The maximum admissible working load must not be exceeded. The moment force arising from the working load must be checked.

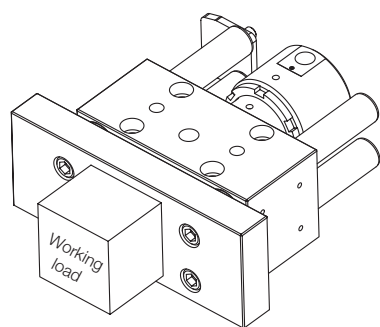

Size	RS.3	RS.4	RS.5	RS.6	RS.7	RS.8	RS.9
Piston speed in mm/s	max. working load in kg						
100	15	60	100	300	610	1750	4150
200	8	30	50	150	305	875	2075
300	5	20	33	100	203	583	1383
400	4	15	25	75	153	438	1038
500	3	12	20	60	122	350	830

The indications refer to a pressure of 150 bar and a viscosity of 22 mm²/s as per DIN 51 524

Multipliers for other viscosity's

Viscosity [mm ² /s]	9	22	32	46	68	100
Factor	0.6	1	1.2	1.5	2	3

Multipliers for other pressures

Oper. pressure [bar]	5	10	25	50	100	150	200	250
Factor	5	3	2	1.5	1.2	1	0.7	0.5

Calculation example:

Working load for type: RS.6 at v = 300 mm/s

Multiplication factor for a viscosity of 46 mm²/s

Multiplication factor for an operating pressure of 100 bar

The maximum admissible working load is

100 kg

1.5

1.2

100 kg x 1.5 x 1.2 = 180 kg

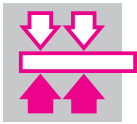

Maximum moment force as a function of the stroke

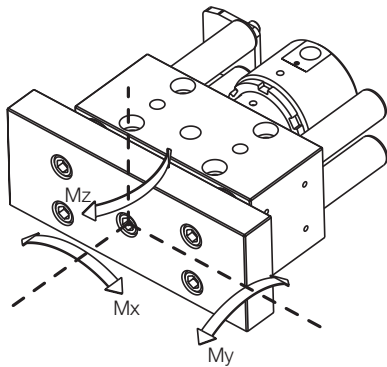

Perbunan version: Mx, My and Mz as per the below graphics

PTFE guide band

(at VITON® version):

Mx as per the below graphics

Due to the PTFE guide band the graphic values below for My and Mz are reduced by 50%.

All indications refer to the slide axis or the front edge of the front block in retracted mode.

**Maximum moment Mx
Standard version RSS3 up to RSS5**

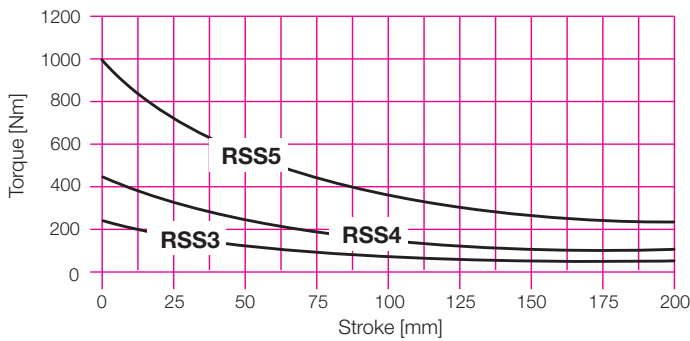

**Maximum moment My and Mz
Standard version RSS3 up to RSS5**

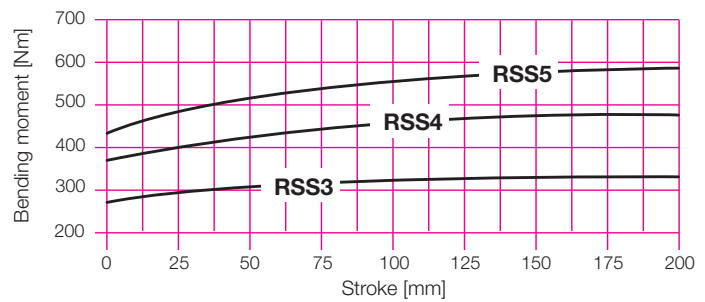

**Maximum moment Mx
Standard version RSS6 up to RSS9**

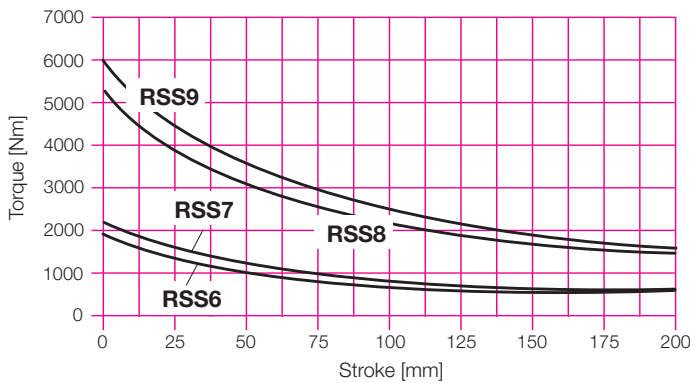

**Maximum moment My and Mz
Standard version RSS6 up to RSS9**

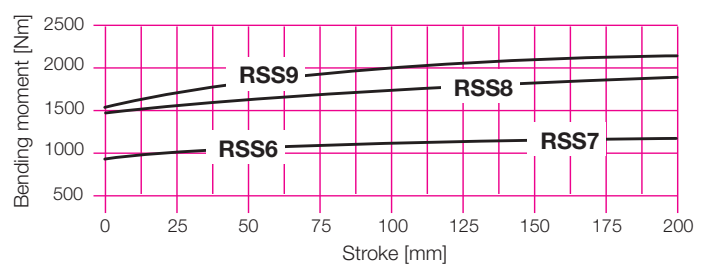

**Maximum moment Mx
Reinforced version RSV6 up to RSV9**

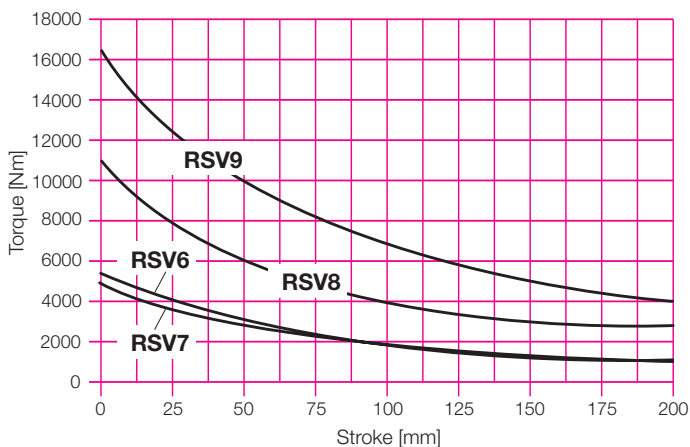

**Maximum moment My and Mz
Reinforced version RSV6 up to RSV9**

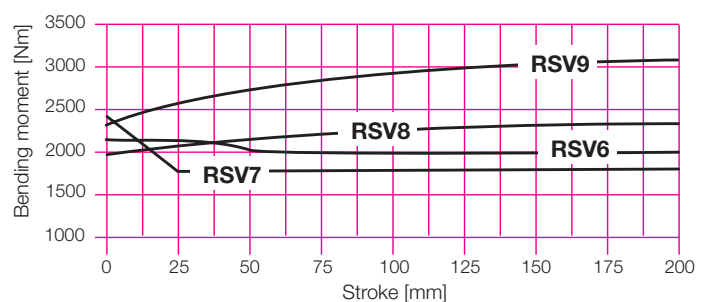

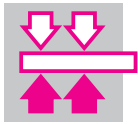

Piston speed as a function of the oil volume

The maximum piston speed of 0.5 m/s must not be exceeded.

Retract

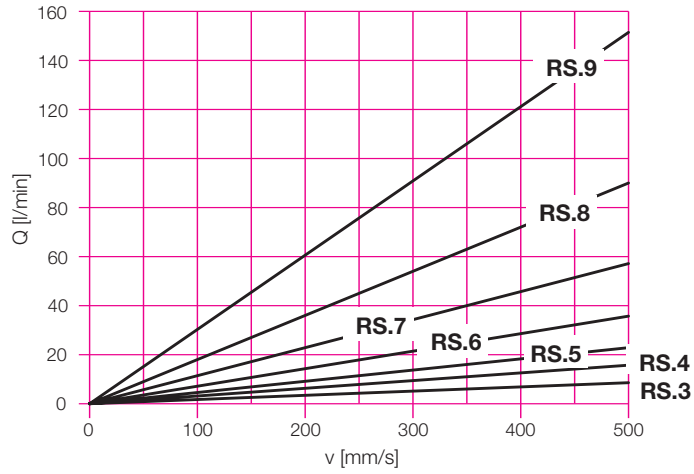

Extend

