

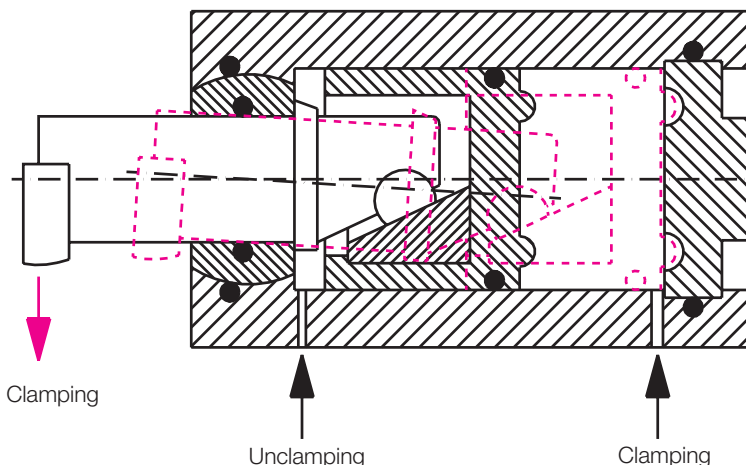

## Block Clamp versions with / without self-locking max. operating pressure 100 / 160 bar



### Application

Due to its flat and compact design, this clamping element offers maximum free machining space. Clamping can be made in apertures or bored holes.

The clamping elements with self-locking are particularly suited for use on clamping fixtures on pallets which are disconnected from the power source or for clamping of moulds on injection moulding machines.

### Description

The block clamp is a double-acting hydraulic clamping element which is hermetically sealed to the exterior.

The element compensates transverse forces at the clamping point.

### Important notes

The linear motion of the clamping lever over the workpiece should not be impeded. In the case of impediment of the linear units transverse forces will act on the workpiece.

The protection against torsion of the clamping arm is only effective in retracted position. In the extended position, the clamping lever may be distorted by a maximum of  $\pm 8^\circ$  thus ensuring that it returns safely into its off-position.

Operating conditions, tolerances and other data see data sheet A 0.100.

### Function

The clamping cycle consists of a linear and a following swing motion.

The clamping force of this element is not directly generated, but by means of a wedge. The clamping force of block clamps with self-locking will also be maintained, even if the element is separated from the pressure generator or if the oil pressure drops. This element meets high safety requirements.

### Versions

- with self-locking
- without self-locking

### Advantages

- Large retention force
- Clamping in different directions
- Self-locking
- Interchangeable contact bolts (can be adapted to different workpieces)
- Transverse forces at the clamping point are compensated
- Variable installation
- Different possibilities for oil supply

### Application example for different clamping directions

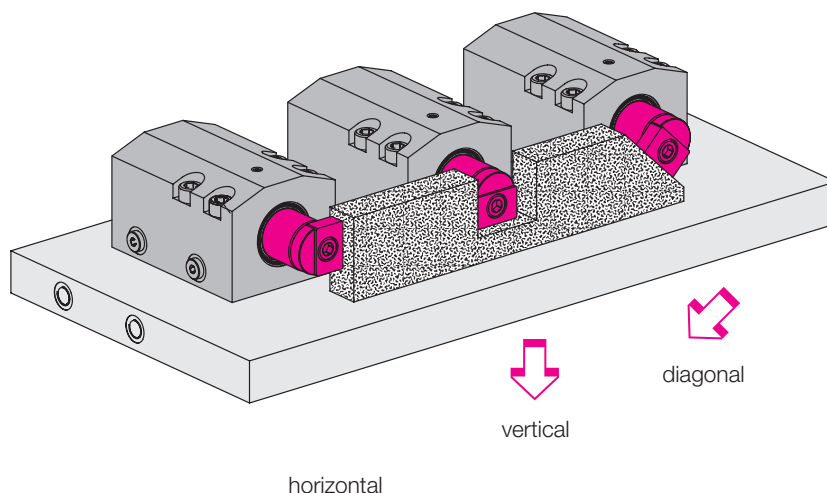



# ROEMHELD

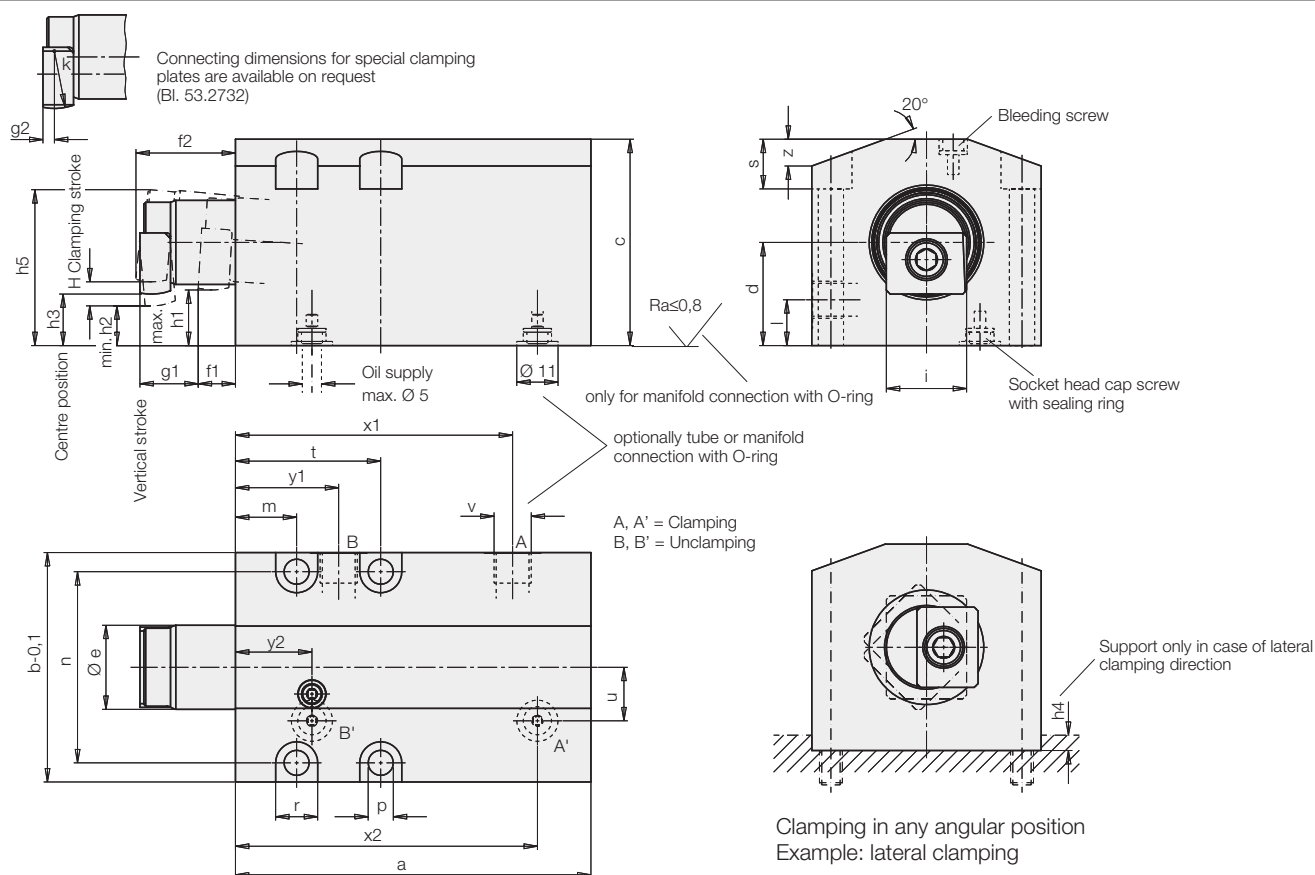

Clamping function		without self-locking	with self-locking	without self-locking	with self-locking
Clamping force	[kN]	12.5	8	32	20.5
Max. operating pressure	[bar]	100	100	160	160
Oil volume					
Clamping / unclamping	[cm <sup>3</sup> ]	28.9/22.8	28.9/22.8	102/76.4	102/76.4
H Clamping stroke max.	[mm]	6	6	8	8
a	[mm]	93	93	126	126
b -0,1	[mm]	60	60	88	88
c	[mm]	54	54	75	75
d	[mm]	27	27	37.5	37.5
Ø e	[mm]	22	22	35	35
f1	[mm]	10	10	13	13
f2	[mm]	26	26	40	40
g1	[mm]	15	15	26	26
g2	[mm]	3	3	3	3
h1	[mm]	14	14	19	19
h2	[mm]	11	11	15	15
h3	[mm]	13.5	13.5	18.5	18.5
h4	[mm]	4	4	6	6
h5	[mm]	41	41	60	60
i	[mm]	21	21	34	34
k	[mm]	15	15	25	25
l	[mm]	12	12	13	13
m	[mm]	16	16	21	21
n	[mm]	50	50	72	72
p	[mm]	6.6	6.6	11	11
r	[mm]	11	11	18	18
s	[mm]	13	13	20	20
t	[mm]	38	38	53	53
u	[mm]	14	14	15	15
v		G 1/8	G 1/8	G 1/4	G 1/4
x1	[mm]	72.5	72.5	99	99
x2	[mm]	79	79	108	108
y1	[mm]	27	27	37	37
y2	[mm]	20	20	28	28
z	[mm]	7	7	10	10
<b>Part-no.</b>		<b>1824-310</b>	<b>1824-410</b>	<b>1824-510</b>	<b>1824-610</b>

## Adjustment of clamping direction

Clamping direction can optionally be in all directions vertically to the axis of the clamping lever. The clamping lever must be in retracted position and the cylinder cover must be rotated by the corresponding angle.

When adjusting the clamping direction at the cover, it has to be considered that the clamping direction of the contact bolt goes in the same direction.

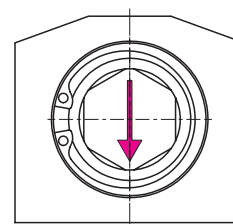

## Accessories

Accessories	Part-no.
O-ring 8 x 1.5	<b>3000-343</b>
Plug G 1/8	<b>3610-047</b>
Plug G 1/4	<b>3300-821</b>