



Hand Slide Clamp

single acting, max. operating pressure 500 bar



Description

In the case of the hand slide clamp the piston force is deviated by 180° by the clamping lever and is available as clamping force with virtually no loss of efficiency. The retracted clamping lever allows unimpeded insertion of workpieces.

Renouncing the automatic displacement of the clamping arm, there is the advantage, within certain limits, to obtain clamping points some distance from the exterior contour of the workpiece.

The retracted clamping lever allows unimpeded loading/unloading of workpieces.

For fabrication of a special clamping lever, a prolonged clamping lever blank is available.

The clamping lever is equipped with a dome-head contact bolt.

The forward position of the clamping lever can be controlled by an inductive proximity switch. A safe clamping signal will be given by the additional use of a pressure switch.

Hydraulic oil can be supplied by fittings or via drilled channels in the fixture body to the hand slide clamp.

Important notes

The inductive proximity switch signals only the position "clamping lever forward". A hydraulic pressure switch is required for a safe clamping control.

The clamping point must be within the clamping range (ho + hu as per chart).

The slots of the sliding pad have to be checked from time to time with regard to contamination by swarf and cleaned, if required.

Operating conditions, tolerances and other data see data sheet A 0.100.

Danger of injury

Hydraulic clamping elements can generate considerable forces.

Due to the required hand operation of the clamping lever considerable injuries can be caused in case of incorrect operation.

Remedy: Protection device with electrical locking, two-hand safety control, etc.

Advantages

- Simple, solid construction
- High efficiency
- Clamping points some distance from the exterior contour of the workpiece can be obtained
- Unimpeded loading and unloading of the fixture
- Inductive monitoring of the clamping lever available as accessory
- Clamping lever can be easily exchanged
- Clamping lever swarf repelling due to smooth surfaces
- Variation of the clamping height due to the use of longer contact bolts up to max. dimension g
- Extended clamping lever blank can be delivered
- Clamping lever can be pushed into small recesses
- Only one hydraulic line is required
- Oil supply alternatively via fittings or drilled channels

Application

The hand slide clamp is particularly suitable for clamping of parts families, for which a quick change of the clamping arm is required.

The workpieces can be inserted from above without any impediments. A clamping recess a little bit wider than the clamping lever is sufficient as clamping surface. Only the clamping lever has to be pushed by hand against the front stop and hydraulically clamped.

By means of elongated clamping levers, clamping points can be obtained which are deep in the workpiece contour. However, the clamping force decreases inversely proportional to the length of the lever (see diagram).

Function

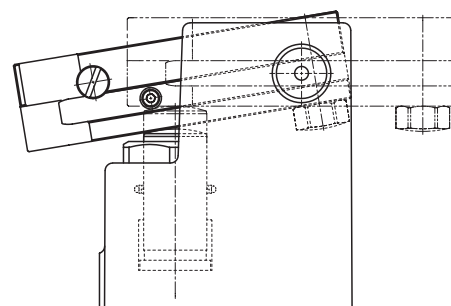

Variants of connection

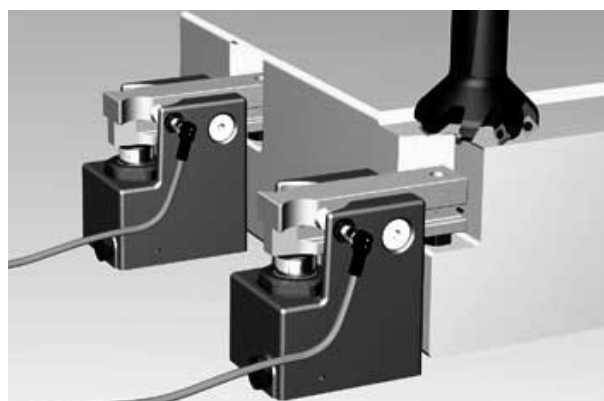
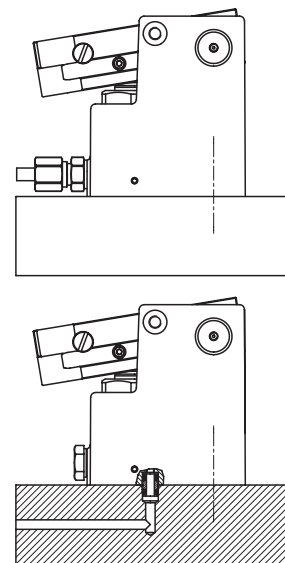



ROEMHELD

Accessory:
Proximity switch
can be mounted
optionally at the left-
hand or right-hand
side

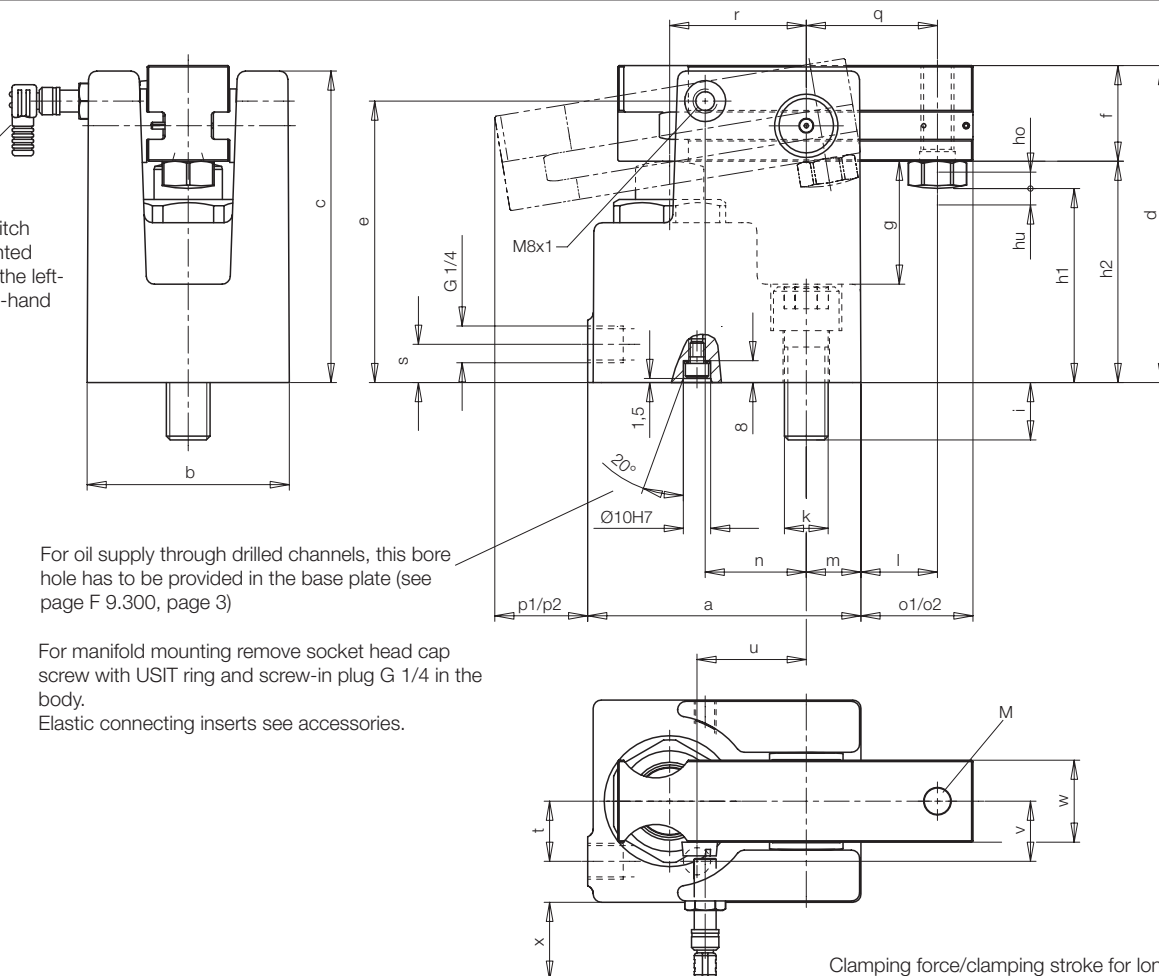

For oil supply through drilled channels, this bore hole has to be provided in the base plate (see page F 9.300, page 3)

For manifold mounting remove socket head cap screw with USIT ring and screw-in plug G 1/4 in the body.
Elastic connecting inserts see accessories.

Clamping force at 500 bar (dimension q)	[kN]	15	25
Oil volume clamping	[cm ³]	5	8
a	[mm]	82	100
b	[mm]	64	74
c	[mm]	109	114
d	[mm]	109	116
e	[mm]	98	103
f	[mm]	32	35
g	[mm]	47	45
h1, with contact bolt	[mm]	67	71
h2, extended clamping lever, without contact bolt	[mm]	77	81
ho / hu, upper / lower clamping point	[mm]	6/6	6/6
i	[mm]	18	21
k / socket head cap screw DIN 912/ seating torque	[Nm]	M12/145	M16/355
l	[mm]	26.5	28
M		M10	M12
m	[mm]	16	20
n	[mm]	24	37
o1	[mm]	39	41
o2, extended clamping lever	[mm]	79	91
p1	[mm]	31	34
p2, extended clamping lever	[mm]	71	84
q, clamping point	[mm]	42.5	48
r	[mm]	41	50
s	[mm]	14	14
t	[mm]	19	22
u	[mm]	31	40
v	[mm]	19	22
w	[mm]	25	30
x, approx.	[mm]	30	29

Part-no. 1830-320 1830-330
Part-no. extended clamping lever, without thread 3548-443 3548-444

Accessories Part-no. } see page F 9.300
 Screw plug G 1/4 3610-006
 Elastic connecting insert 9210-132

Accessories Part-no. } see page B 1.552
 Inductive proximity switch 3829-098
 Plug + cable 3829-099

Clamping force/clamping stroke for longer special clamping levers 1830-320

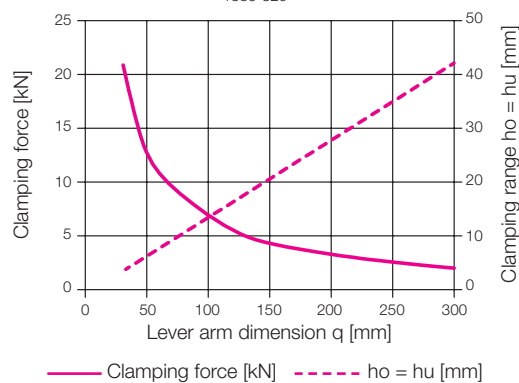

Clamping force/clamping stroke for longer special clamping levers 1830-330

