

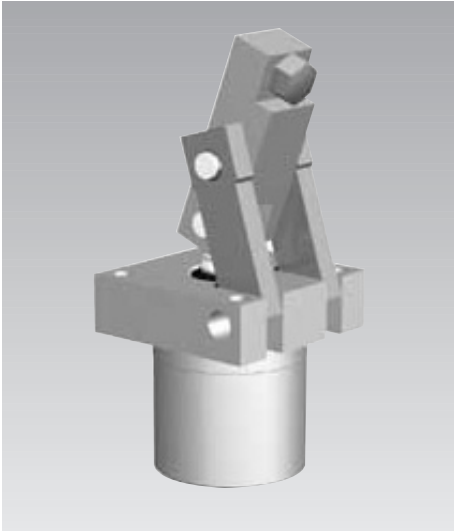

Hinge Clamp

double acting, max. operating pressure 200 bar



Advantages

- Compact design
- Large clamping area of 6 mm
- The clamping lever is completely retracted in off-position
- Interchangeable contact bolts
- 3 clamping levers available
- Clamping lever can be adapted to the workpiece
- Mounting position: any
- Low-cost

Function

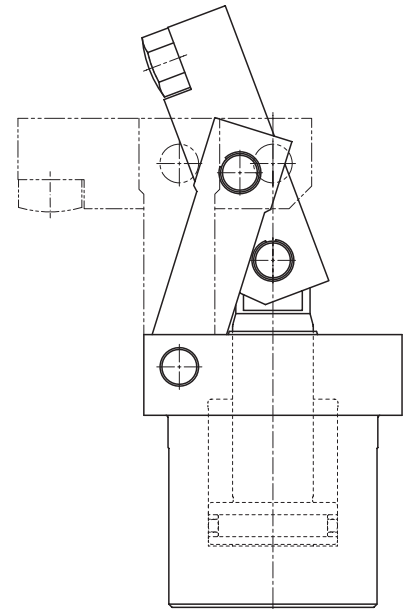

Description

When pressurising the element, the piston moves from the unclamped position upwards. The clamping lever swivels forward by means of the two links and at the same time downwards onto the workpiece.

The clamping lever is provided with an internal thread to accept a contact bolt, which can be easily exchanged.

Oil supply is made from the back by means of fittings.

Application

The hinge clamp is a low-cost element with high clamping force for simple clamping tasks.

Workpieces can be easily inserted from above, since the clamping lever swivels completely behind the front edge of the element.

Due to the simple design of the components, clamping lever and contact bolts can be easily adapted to the workpiece.

Installation

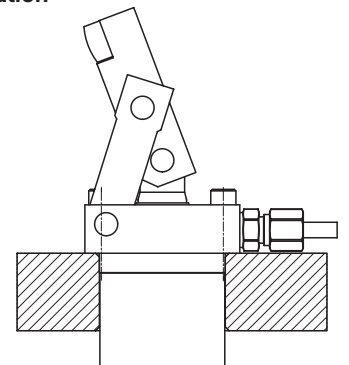

Important notes

Due to the open design, it should be checked regularly to see if the hinge clamp is contaminated by swarf and needs cleaning.

Operating conditions, tolerances and other data see data sheet A 0.100.

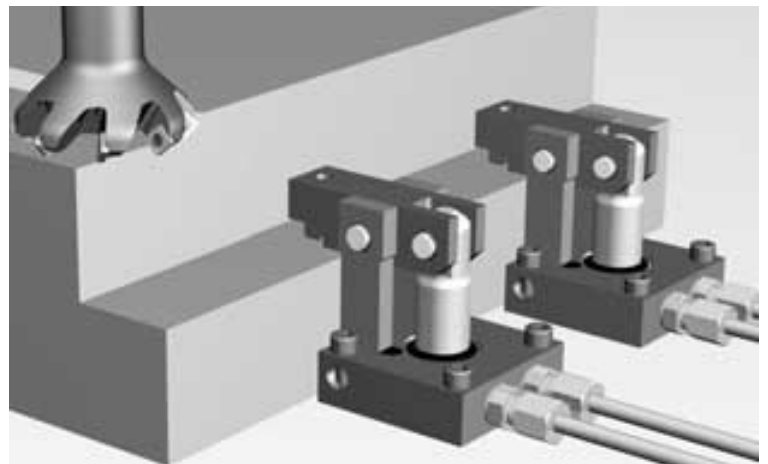



ROEMHELD

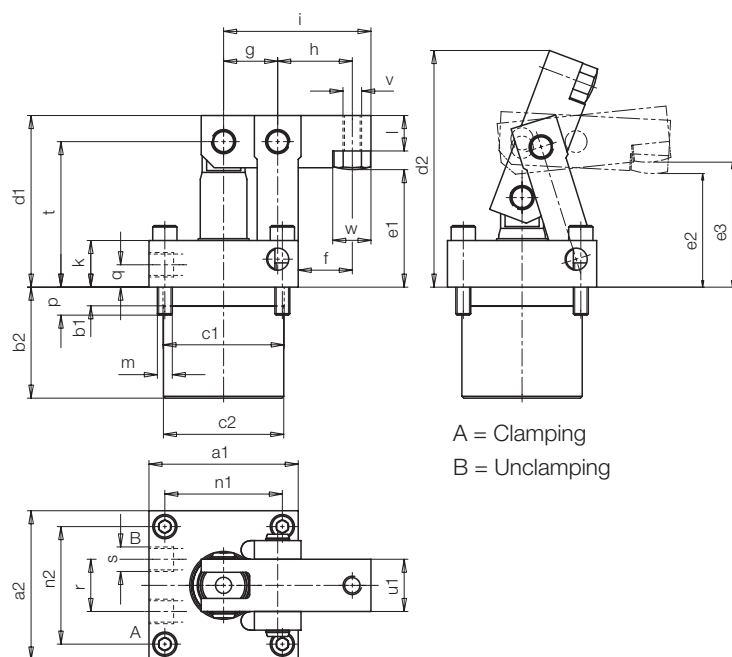

A = Clamping
B = Unclamping

Accessories:

Swivel contact bolt M10 flat face, see data sheet G 3.800, dimension e1 – 8mm

Part-no. 3614-073

When using longer contact bolts or longer clamping levers, the clamping lever does not swivel completely behind the front edge of the body.

Clamping force	[kN]	18
Max. operating pressure	[bar]	200
Oil volume clamping	[cm ³]	40.2
Oil volume unclamping	[cm ³]	24.5
a1	[mm]	80
a2	[mm]	80
b1	[mm]	10
b2	[mm]	59.5
Ø c1 -0.2	[mm]	65
Ø c2 -0.2	[mm]	64.5
d1	[mm]	92
d2	[mm]	127
e1	[mm]	63
e2, lower clamping point	[mm]	61
e3, upper clamping point	[mm]	67
f	[mm]	29
g	[mm]	29
h	[mm]	40
i	[mm]	79
k	[mm]	25
l	[mm]	19
m		M8
n1	[mm]	63
n2	[mm]	63
p	[mm]	15
q	[mm]	12
r	[mm]	28
s		G 1/4
t	[mm]	78
u1	[mm]	28
u2	[mm]	13
v		M10
w	[mm]	20.5
x1	[mm]	60
x2	[mm]	29
y1	[mm]	64
y2	[mm]	78
z1	[mm]	28
z2	[mm]	27.5

Part-no. 1825-500

Cranked clamping lever
(Dimensions u2,x2,y2,z2)

Part-no. 3548-410

Clamping lever, long, unmachined
(Dimensions x1,y1,z1)

Part-no. 3548-409

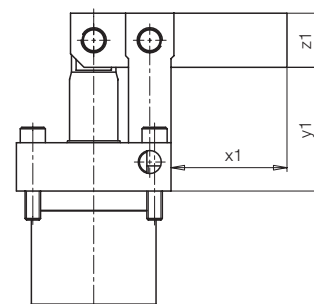
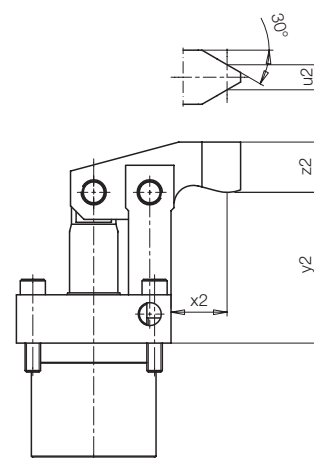

Special features:

If the maximum clamping force has to be applied, the material of the assembly plate must have a minimum yield point of $Re/Rp 0.2 \geq 160 \text{ N/mm}^2$.