

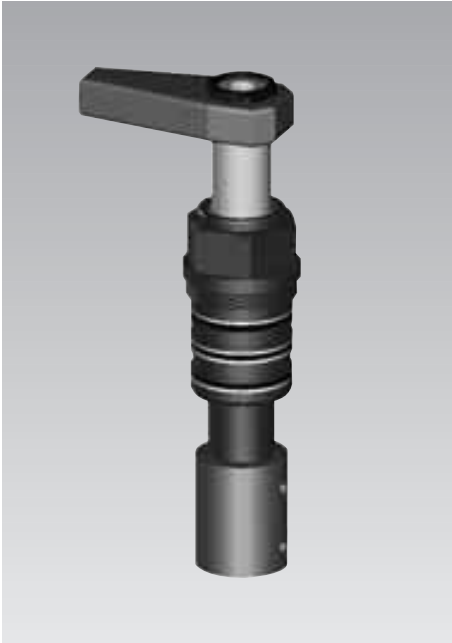

Swing Clamp, double acting, threaded-body type, without overload protection, reinforced swing mechanism, switch rod for position control, max. operating pressure 500 bar

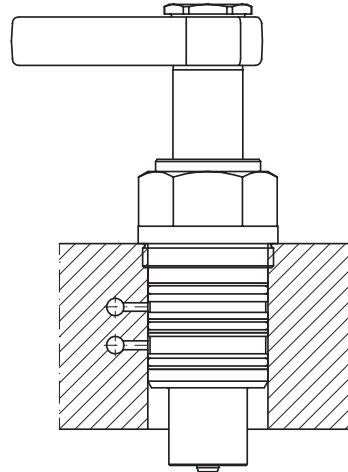

Installation possibilities



Application

Hydraulic swing clamps are used for clamping of workpieces when it is essential to keep the clamping area free of straps and clamping components for unrestricted workpiece loading and unloading. Due to the sturdy swing mechanism and the extended switch rod they are particularly suited for

- Clamping fixtures with workpiece loading via handling systems
- Transfer lines
- Test systems for motors, gears, axis, etc.
- Automatic manufacturing systems
- Assembly lines

Description

This line is a further development of the proved RÖMHELD swing clamps with the aim to improve process safety in linked clamping systems. The most important characteristics are as follows:

1. Omission of the overload protection device
In the case of a slight collision with the clamping arm during loading and unloading of the fixture, the angular position of the clamping arm will be maintained. Less critical are the weight of the clamping arm or an increased swing speed.

2. Reinforced swing mechanism

The reinforced swing mechanism endures a collision of the clamping arm with the workpiece during clamping up to a pressure of 100 bar.

3. Switch rod for position control

The helix rod protrudes through the cover and allows thereby a pneumatic or electrical control of the piston position outside the swarf area. As an accessory a pneumatic position control is available; the brass control slide being displaced in a stainless housing. The slide opens and closes bore holes, so that a pressure switch or a differential pressure switch can signal the position "Clamped" and "Unclamped". It is also possible to realise this control directly in the fixture body by means of drilled channels. An electrical position monitoring with inductive proximity switches is also available (see page 2).

4. Wiper VITON®

Has a high chemical resistance when using aggressive cutting fluids

5. Option: Metallic wiper

Protects the wiper VITON® against mechanical damage, e.g. by hot swarf. The swing clamp body is prepared for mounting of the metallic wiper. The wiper consists of a radially floating wiping disk and a retaining disk which will be pressed onto the existing collar.

6. Different types of bodies

Beside the version "Threaded-body type" the versions "Bottom Flange" (B 1.8811) and "Top Flange" (B 1.8801) are available with the same equipment.

Important notes

Due to the missing overload protection device, assembly and disassembly of the clamping arm has to be made carefully despite the reinforced swing mechanism. When tightening and untightening the fixing nut, the clamping arm or the hexagon socket in the piston have to be backed up. It is recommended to effect tightening and untightening in the swing area. Frequent collisions with the clamping arm in radial direction have to be avoided.

For interpretation of the pneumatic pressure we recommend to use the differential switches type PEL. Series connection for up to 8 swing clamps is possible.

Reference address:
MAWOMATIC MAYER WONISCH
MIETZEL GmbH
Donnerfeld 2
D-59757 Arnsberg
Phone +49 (0) 29 32 / 63 83 90
Fax +49 (0) 29 32 / 63 83 99

Further important notes
see page B 1.892.

VITON® wiper
standard





ROEMHELD

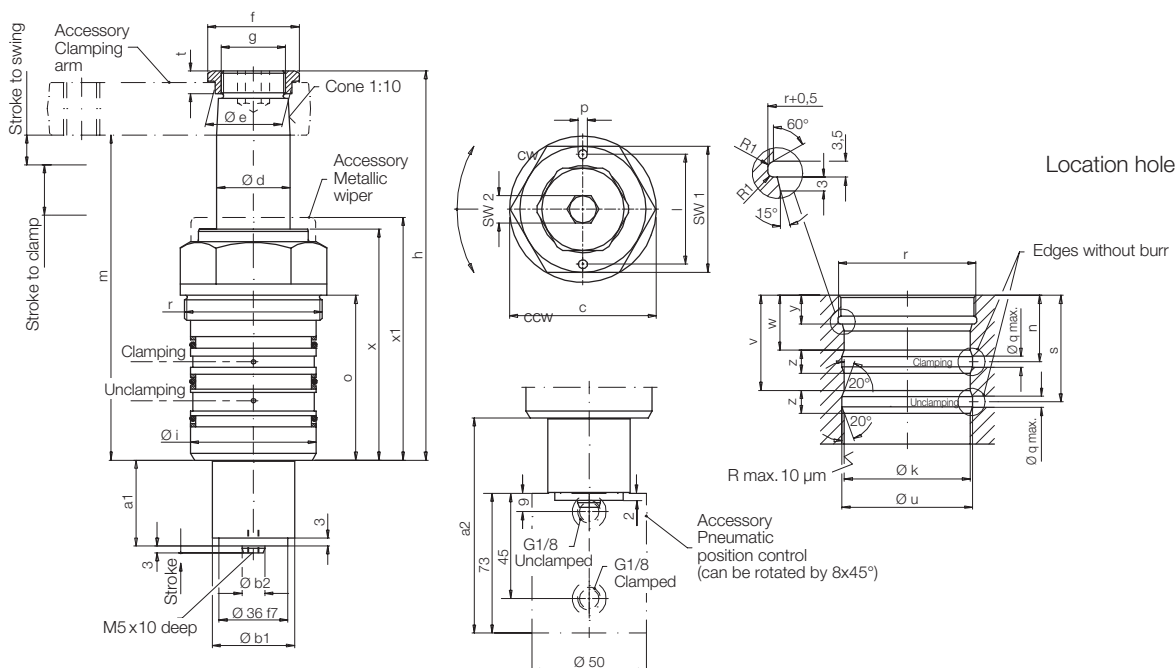

Stroke to clamp	[mm]	22	20
Stroke to swing	[mm]	13	18
Total stroke	[mm]	35	38
Operating pressure to swing, min.	[bar]	30	30
Max. oil flow rate	[cm ³ /s]	20	55
Oil to clamp	[cm ³]	15.8	43.8
Oil to return	[cm ³]	41.2	114.2
a1	[mm]	38	41
a2	[mm]	108	112
Ø b1	[mm]	36	45
Ø b2 f7	[mm]	10	12
Ø c	[mm]	64	100
Ø d	[mm]	32	50
Ø e	[mm]	33.5	55.5
f	[mm]	40	68
g	[mm]	M 28x1.5	M 45x1.5
h	[mm]	171	209
Ø i f7	[mm]	55	85
Ø k H7	[mm]	55	85
l	[mm]	-	80
m -1	[mm]	143	169
n	[mm]	29	41
o	[mm]	72	109
Ø p / deep	[mm]	-	8 / 9
Ø q max.	[mm]	5	6
r	[mm]	M 60x1.5	M 90x2
s	[mm]	46.5	64
t	[mm]	10	12
Ø u	[mm]	57	87
v	[mm]	41.5	59
w	[mm]	24	36
x	[mm]	101	124
x1	[mm]	106	129
y	[mm]	12.5	20.5
z	[mm]	10	10
SW 1	[mm]	55	95
SW 2	[mm]	12	17

	Part-no.	Part-no.
Clockwise rotation 90°	1895-101-VMH35	1897-101-VMH38
Counterclockwise rotation 90°	1895-201-VMH35	1897-201-VMH38
0 degree	1895-241-VMH35	1897-241-VMH38

Accessories

Pneumatic position control, complete	0353-808	0353-810
Electrical position monitoring		
– without switch	0353-815	0353-813
– with standard switch	0353-814	0353-811
Metallic wiper, complete	0341-100	0341-102

Accessory:

Electrical position monitoring

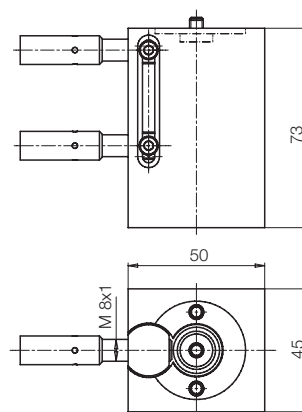

Function charts

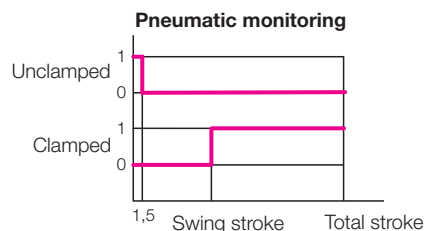

1 = Closed
0 = Passage

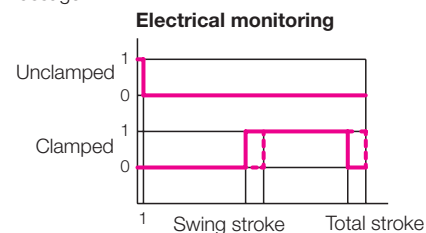

Key for available angles of rotation

Angle of rotation (±1°)	Part-no.
90°	189X-X0X-VMHXX
60°	189X-X2X-VMHXX
45°	189X-X3X-VMHXX

Clamping force diagram see data sheet B 1.892, pg. 2 – other accessories see data sheet B 1.892, pg. 4
Further proximity switches see data sheet B 1.552, pg. 2