

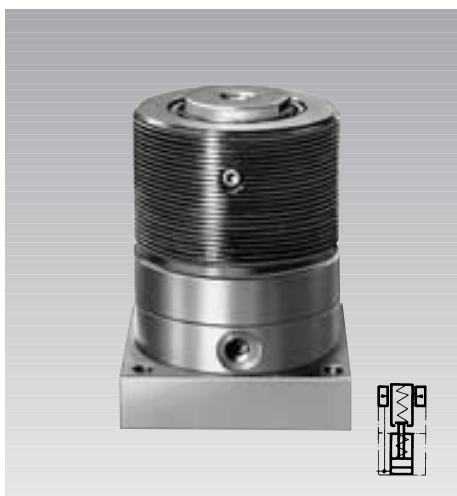

Work Supports extending hydraulically - contact by spring force single acting with spring return, max. operating pressure 500 bar

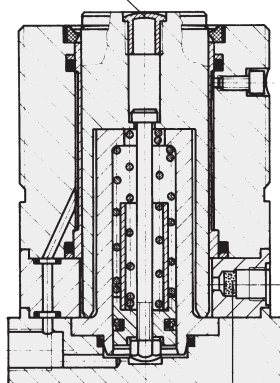

The plunger internal thread should always be plugged by a plastic cap or a screw-in extension to protect the element against penetration of liquids.



Sintered metal air filter
Connection for ventilation hose ND 6
by hose fitting 3300-921.

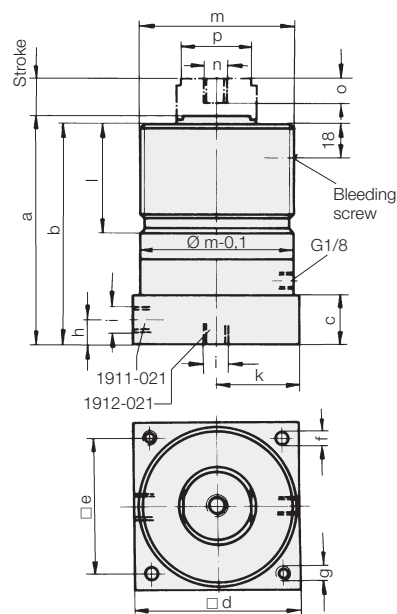

Description

With the 1910 range the support plunger is retracted in off-position. When pressurised the support plunger moves against the inserted workpiece by means of light force. With increasing oil pressure, the plunger locks hydraulically. After the system has been unclamped, the support plunger returns to off-position. The support plunger is provided with female thread to enable the use of threaded pieces for height adjustment. Oil supply can alternatively be effected from the side or from below. The internal part of the work support is protected against dust and swarf by a sintered metal air filter.

Important notes

If there is any danger of fluids being sucked into the filter, a vent hose has to be connected. Spring force should not be used to lift workpieces.

Contact bolts and extensions with large weight can influence the functions of this component.

Operating conditions, tolerances and other data see data sheet A 0.100.

Admissible load F as function of the operating pressure p

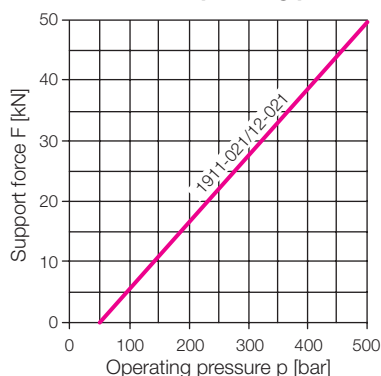

Max. elastic deformations s as a function of support force F

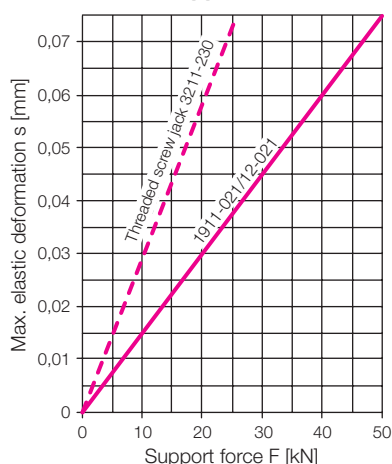

Connections	on side	at the bottom
Plunger Ø	[mm] 40	40
Plunger stroke	[mm] 18	18
Oil for full stroke	[mm] 5.7	5.7
Max. oil flow rate	[cm ³ /s] 70	70
Min. oil pressure	[bar] 100	100
Spring force	60 – 100 N, depending on stroke	
a	[mm] 115	120.5
b	[mm] 111	116.5
c	[mm] 21	26.5
d	[mm] 85	85
e	[mm] 68	68
f	[mm] 9	9
g	[mm] M 8	M 8
h	[mm] 11	–
i	G 1/4	G 1/4
k	[mm] –	42.5
l	[mm] 54	54
Ø m	[mm] M78x2	M78x2
n	[mm] M12	M12
o	[mm] 12	12
p	[mm] 36	36
Weight	[kg] 4.2	4.2
Part-no.	1911-021	1912-021

Teflon wiper
for high loads
available on request