



## Threaded-Body Work Supports max. operating pressure 500 bar



### General technical characteristics

Plunger Ø	[mm]	16
Stroke	[mm]	8 (15)
Adm. support force at 500 bar		
194X-00X	[kN]	6.5
194X-01X	[kN]	9.5
Recom. minimum oil pressure [bar]		100
Seating torque	[Nm]	60
Weight	[kg]	ca. 0.25

Mounting dimensions, accessories and application examples see reverse page

### Admissible load F as function of the operating pressure p

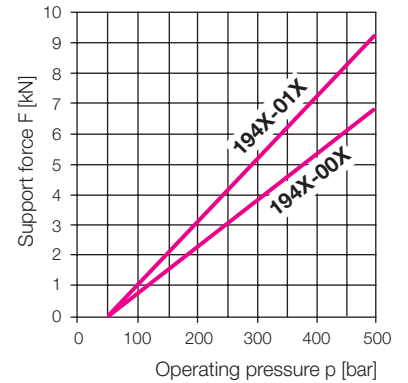

### Application

Hydraulic work supports are used to provide a self-adjusting rest for the workpiece during the machining operations. They compensate the workpiece surface irregularities, also deflection and vibration under machining loads. Two sizes are available. The threaded-body design of the elements allows direct installation in clamping fixtures, in horizontal or vertical mounting position, and thereby a space-saving arrangement. Hydraulic oil is fed through drilled channels in the fixture body. Hydraulic locking is made together with hydraulic clamping of the workpiece, or independently.

### There are three variations of plunger actuation:

- 1. Spring advanced;** plunger extended in off-position
- 2. Air pressure advanced;** plunger retracted in off-position. The pneumatically-actuated plunger allows precise setting of the plunger contact force by means of a pressure reducing valve.
- 3. Hydraulic pressure and spring advanced;** plunger retracted in off-position. It moves forward with a light spring force against the workpiece, when hydraulic pressure is applied.

### Combination possibilities

The work supports 194X-01X can be combined with the swing clamps as per data sheet B 1.891. (Example see reverse page).

### Important notes

Operating conditions, tolerances and other data see data sheet A 0.100.

Teflon wiper for high loads available on request

### Contact by spring force



a	[mm]	80.5	90.5
b	[mm]	79	89
c	[mm]	54	64
Spring force min./max.	[N]	8/13	8/13
<b>Part-no.</b>		<b>1940-000</b>	<b>1940-010</b>

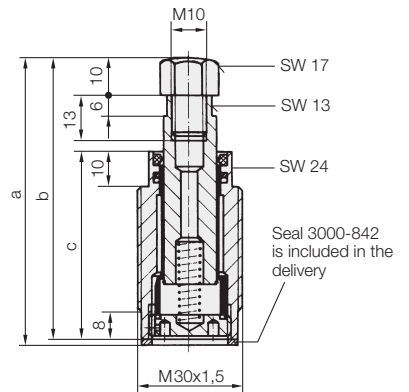

### Contact by air pressure



a	[mm]	84	94
b	[mm]	72.5	82.5
c	[mm]	71	81
d	[mm]	54	64
Spring force min./max.	[N]	20/30	20/30
Plunger contact force at 1 bar air pressure (deduct spring force if necessary)	[N]	20	20
<b>Part-no.</b>		<b>1941-000</b>	<b>1941-010</b>

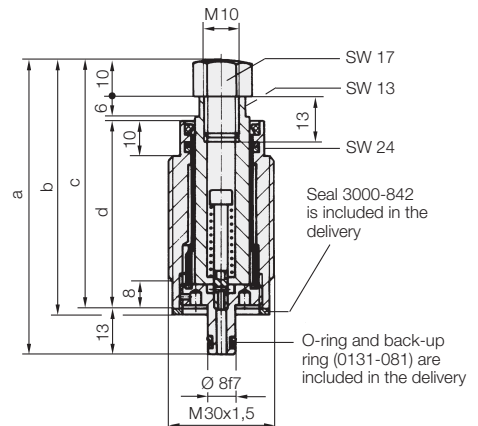

### Contact by oil pressure

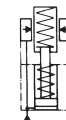

Stroke	[mm]	8	15	8	15
a	[mm]	72.5	79.5	82.5	89.5
b	[mm]	71	78	81	88
c	[mm]	54	61	64	71
Spring force min./max.	[N]	10/23		10/23	
Max. oil flow rate	[cm³/s]	25		25	
<b>Part-no. Stroke 8</b>		<b>1942-000</b>		<b>1942-010</b>	
<b>Stroke 15</b>		<b>1942-005</b>		<b>1942-015</b>	

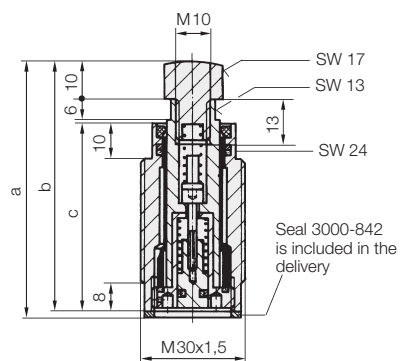



# ROEMHELD

## Installation dimensions 1940-0X0/1942-0X0

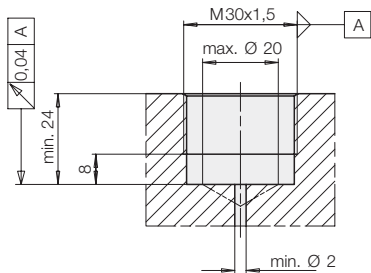

## Installation dimensions 1941-0X0

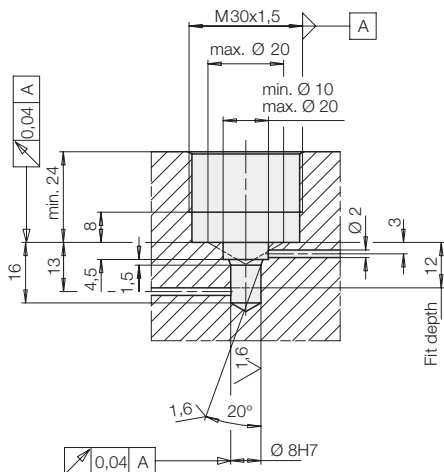

## Accessories

Mounting body **part-no. 3467-086** as per data sheet B 1.460 or

body with pneumatic connection

**Part-no. 3467-112**

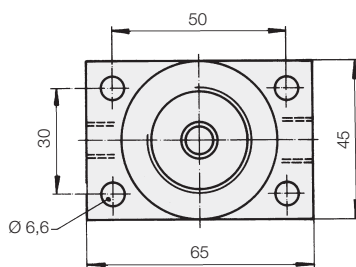
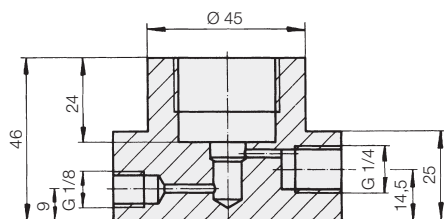

## Installation example

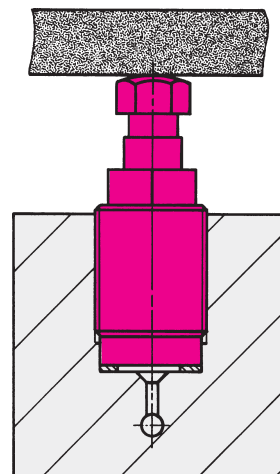

## Combination possibility

Threaded-body work support with threaded-body swing clamps as per data sheet B 1.891

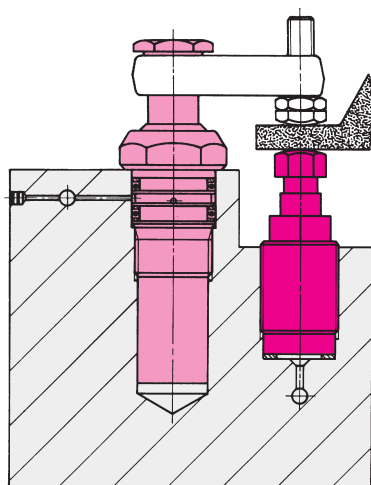

Support and clamping forces have to be adapted to each other, so that there will be sufficient force reserve available for the threaded-body work support to absorb the machining forces.

Thumb rule: Support force  $\geq 2 \times$  opposing force

The required minimum pressure is 200 bar.

The diagram below shows the graphs of the clamping and support forces for the 2 possible combinations.

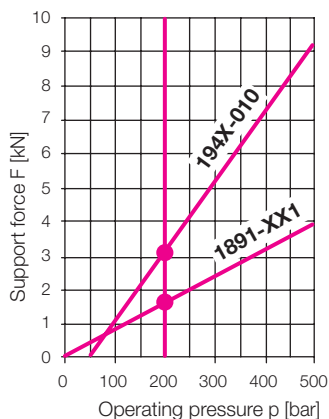

## Example

Swing clamp 1891-XX1 clamps against threaded-body work support 194X-010. Operating pressure 200 bar.

Support force 3 kN

Clamping force -1.5 kN

1.5 kN = possible opposing force