

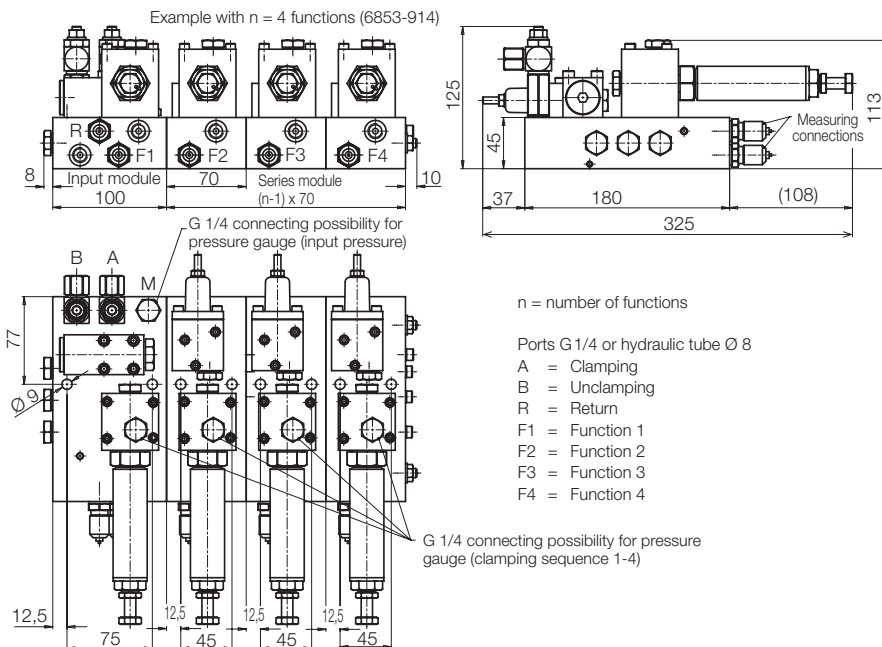

Valve Module Combination

max. operating pressure 250 bar



Description

The valve module combination consists of an input module and up to three series modules (for linkage of further modules please consult us). In the input module the following hydraulic function elements are integrated:

- Flow control valve with connected line filter for both inputs to reduce the flow rate and to filter the fluid.
- Pilot-controlled check valve to protect the clamping circuit in the case of pressure drop e.g. due to line break.
- Pressure reducing valve to reduce the pressure for the first control function at the fixture.
- Two miniature measuring connections to connect a pressure gauge for pressure adjustment.

The series modules are directly linked to the input module. Thereby further clamping functions can be realised. The modules are equipped with the following hydraulic function elements:

- Sequence valve to realise one or several switching sequences (connected in series in the linked arrangement).
- Pressure reducing valve to reduce the pressure in the corresponding switching sequence.
- Miniature measuring connection to connect a pressure gauge for pressure adjustment.

In the base plates of the modules additional channels are provided which can be used as hydraulic / pneumatic channels or for the routing of electric lines.

If permanent visual pressure monitoring is required, pressure gauges can be retrofitted (see accessories).

Application

The valve module combination is a valve unit composed of individual modules. It is used to control complex hydraulic clamping fixtures. In order to fix safely workpieces in clamping fixtures, functions as positioning, clamping and supporting have to be effected in a determined sequence. In some applications it is required to realise the individual functions with reduced clamping pressures in order to guarantee optimum workpiece clamping. For this purpose sequence valves and pressure reducing valves are integrated in the hydraulic clamping circuit. Therefore considerably longer lines are required for tubing as well as for drilled channels. Due to the use of valve module combination the required line length is considerably reduced, since all required control and pressure valves are directly arranged at the unit.

Advantages

- Reduced tubing for hydraulic fixtures.
- Simulation of the clamping sequence possible in advance.
- Reduced surface of attack for dirt and swarf at the fixture.
- Less contamination in the fixture due to integrated line filters
- Reduced input flow rate due to existing flow control valves possible
- Required space for hydraulic control can already be considered during fixture design.

Important notes

See important notes on data sheets C 2.9501, C 2.9512, C 2.9533, C 2.954.

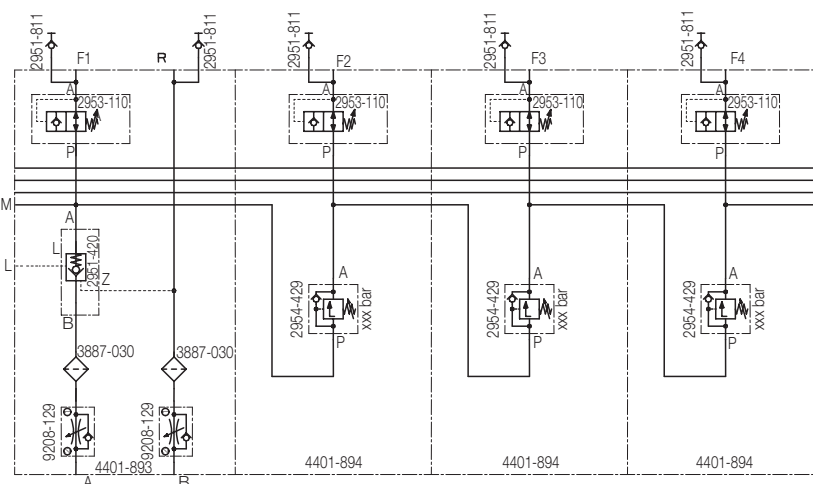



ROEMHELD

Input module **Part-no. 4401-893**
 Series module **Part-no. 4401-894**

Valve module combination 2-fold **Part-no. 6853-912**
 Valve module combination 3-fold **Part-no. 6853-913**
 Valve module combination 4-fold **Part-no. 6853-914**

consisting of: 1 input module, 1 series module
 consisting of: 1 input module, 2 series modules
 consisting of: 1 input module, 3 series modules

Accessories

for pressure adjustment system "Minimess":

High-pressure hose **Part-no. 6355-681**
 Pressure gauge union **Part-no. 6355-467**
 Pressure gauge 400 bar **Part-no. 9823-000**

for mounted pressure gauges:

Tube male stud coupling **Part-no. 9208-102**
 Pressure gauge union **Part-no. 9208-041**
 Pressure gauge 400 bar resistant to coolant jets **Part-no. 9208-041**

Application example

The figure shows a hydraulic clamping fixture for machining of a power unit carrier for an agricultural tractor. The workpiece will be machined from four sides in a horizontal machining centre. Machining of the back of the workpiece is made from the back through the basic body. Clamping elements slide pivot clamps, universal cylinders, work supports and for "floating clamping" of the two upper straps threaded-body cylinders with locking pistons are used. The hydraulic elements are controlled by the valve module combination mounted at the back.



Sequence of the clamping cycle

Step 1:
 Clamping with the first slide pivot clamp against fixed datums, as well as lateral positioning by means of an universal cylinder.

Step 2:
 First sequence valve opens, work support moves against the lower side of the workpiece and is hydraulically locked.

Step 3:
 Second sequence valve opens, two each oppositely arranged threaded-body cylinders with locking piston clamp both upper straps of the workpiece by "floating clamping". At the same time the second slide pivot clamp clamps onto the work support.

