



Power Units with pressure adjusting system max. operating pressure 500 / 250 bar



Description

The operator operates a spindle mechanism, which unlocks mechanically the check valve and allows adjustment of the pressure relief valve. A new system pressure can only be adjusted at the pressure relief valve. By turning the spindle mechanism to its original position, adjustment is terminated.

The pressure adjusting system consists of three important elements:

1. A mechanically adjustable pressure relief valve
2. A spindle mechanism for pressure compensation between pump circuit and cylinders.
3. An electronic evaluation unit for pump control, error control of the system, and digital pressure display

Advantages for the user:

- Simple and quick adjustment of system pressures
- No hydraulic and control-technical knowledge is required
- Avoidance of incorrect adjustment
- High precision of pressure adjustment also for low system pressures
- High degree of safety due to error control procedure
- High reliability due to low-wear components
- Precise digital pressure display
- Error indication at display
- Switching possibility bar ↔ psi

Application

The new pressure adjusting system is used for simple, quick and safe adjustment of the operating pressure for the proved power units as per data sheet D 8.011 and D 8.021. Simple adjustment of the operating pressure is required e.g. when using fixtures on which several workpieces have to be clamped with different pressures, for different operating cycles and for trials of fixtures.





Control variants

Single-acting cylinders

Connecting several single-acting cylinders to one pressure port is possible.

Sequence controls, e.g. positioning before clamping can be easily attained with sequence valves as per data sheet C 2.954. The unit for shuttle machining allows the operation of two independent circuits with two switches.

Double-acting cylinders

Several double-acting cylinders can be connected to the two pressure ports of the unit. Single-acting cylinders can be connected additionally, however they retract slower than the double-acting cylinders. Pressure dependent sequence controls can be applied, too. The unit for shuttle machining allows the operation of two independent circuits with two switches.

These power units can be equipped with max. 2 valves.

Power unit without valve

This unit is used in conjunction with external hydraulic controls only. The power unit serves as an independent pressure source with its own electrical control, maintaining a set pressure by a pressure control switch.

Safety provisions

An increased safety in power workholding is achieved through the following characteristics: Operating pressure stepless adjustable from 25 bar (8402-2XX) or 50 bar (8402-1XX) respectively, therefore precisely defined clamping force with accurate repeatability. Visual control of operating pressure through built-in pressure gauge. A pressure drop of approx. 10% will cause the pump motor to start again. No immediate pressure loss on power failure. The solenoid valves are de-energised in the "clamped position" and the poppet types provide tight sealing.

Oil level control „T“

Is available as accessory and can be retrofitted at each power unit. The oil level control (signal transmitter) has to be screwed in a threaded hole in the cover of the reservoir and the supplied cable connected in the control box as per electric circuit diagram on page 4 (S1). The bridge between terminal 5 and 6 has to be removed.

Function: If the oil level drops due to external leakage the electric motor will be cut off. A LED placed below the main switch is lit. The rotor starts running after replenishing the oil level.

General characteristics

Configuration	Radial piston pump
Direction of rotation	any
Porting connection	G 1/4 for male connectors form B as per DIN 3852
Mounting	3 screws M 8 (not required for mobile use)
Mounting position	upright
Environmental temperature.	+0...+35 °C
Noise level	max. 80dB [A] (in 1 m distance and height above the floor)

Hydraulic characteristics

Viscosity range	(4...300) 10 ⁻⁶ m ² /s
Recom. viscosity class	ISO VG 22 as per DIN 51519
Recom. hydraulic oil	HLP 22 as per DIN 51524 (not suited for fluids of the type HS-A, HS-C and HS-D)
	normal* max.**
Oil charge [l]	3.8 5.0
Usable oil volume	1.75 2.95
The difference on the oil level gauge is max. -min.	= 0.97 l
* black mark on the oil level gauge	
** up to the reservoir cover	

Electric characteristics

Electric motor

Type	2-pole three-phase motor
Rating	0.75 kW
Speed	2830 1/min.
Voltage	3/PE ~ 50 Hz, 400 V Other voltages and frequencies on request available
Nominal current	2.0 A
cos φ	0.82
Isolation class	B as per VDE 05 30
Rel. duty cycle	see section 9
Main switch	Main switch with excess current
Control	Circuit breaker, control by pressure adjusting system Control voltage: 24 V DC

Valves

Valves	Controlled by push-button or foot-actuated switch
--------	---

Max. uninterrupted running time (t_B max.) of pumps for the following oil levels in the reservoir

Maximum:		
Up to reservoir cover	120 s	84 s
Useable oil volume approx. 2.95 l		
Normal:		
Black mark at oil level gauge	120 s	50 s
Useable oil volume approx. 1.75 l		
Minimum:		
Red mark at oil level gauge	57 s	22 s
Useable oil volume approx. 0.78 l		

Part-no.

Fuse

Fuse	Electric control has to be externally secured with 3 x 6 A slow. Internal electric control circuit: 24 V DC
Fuses	Primary: 2 x 4 A slow, 5 x 30 mm Secondary: 1 x 2 A slow, 5 x 20 mm
Main switch	can be padlocked
Code class	IP 54

Connection

Electric connections	5 x 1.5 mm ² , 3,5 m long
Push-button switch	5 x 1 mm ² , approx. 3 m long
Foot-actuated switch	5 x 1 mm ² , approx. 3 m long
EMC	tested

Relative duty cycle

This power unit can only be used intermittently similar to section S3 of VDE 0530. The electric motor will be cut off by the pressure adjusting system as soon as the preset operating pressure is reached.

Different motor running and idle times are simply added.

The max. relative duty cycle is a function of the motor load. Motor winding temperature of the submerged motor is dependent upon oil temperature and oil level. Winding is totally oil cooled at max. oil level (up to reservoir cover), however air cooled when usable oil volume (2.95 l) is used up. This reduces the relative duty cycle with decreasing oil level.

The max. oil temperature is 60°C.

8402-1XX 8402-2XX

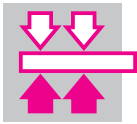

Technical characteristics of pressure adjusting system 8000-901 / -902

Max. operating pressure	500 bar / 250 bar
Flow rate	0.82 ... 8 l/min
Voltage	18 ... 30 V DC
Resolution of digital display	1 bar / ~14 psi
Switching hysteresis of pressure adjustment	≤ 10% of the adjusting value
Operating temperature (internally limited)	max. 65 °C
Contact rating of output contacts	24 V DC; 0.5 A; 42 VA; 20 W

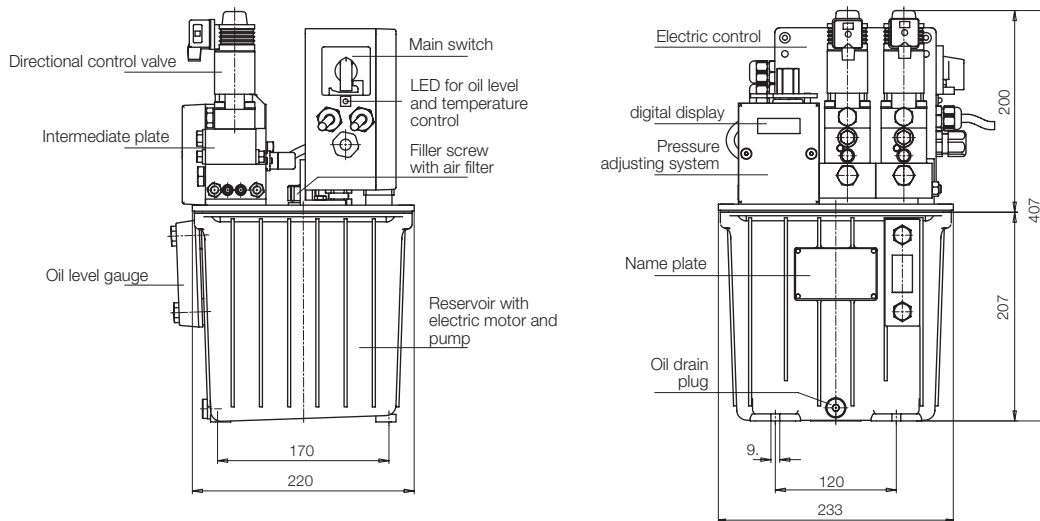

Flow rate	[cm ³ /s]	13.67	35.0
	[l/min]	0.82	2.1
Max. operating pressure	[bar]	500	250

Cylinder type	Switch type	Weight [kg]	Part-no.	Part-no.
With electric control				
single acting	push-button	29.5	8402-121	8402-221
	foot-actuated	30.5	8402-122	8402-222
	without switch	28.5	8402-131	8402-231
double acting	push-button	30.5	8402-103	8402-223
	foot-actuated	31.5	8402-104	8402-224
	without switch	29.5	8402-113	8402-233
2 x single acting (shuttle machining)	2 push-buttons	31.5	8402-105	8402-225
	2 foot-actuated	33.5	8402-106	8402-226
	without switch	29.5	8402-114	8402-214
2 x double acting (shuttle machining)	2 push-button	30.5	8402-107	8402-207
	2 foot-actuated	31.5	8402-108	8402-208
	without switch	29.5	8402-115	8402-215
without valve	without switch	28.0	8402-110	8402-210

With terminal box

external power supply 24 V DC
required for pressure adjusting system

single acting	without switch	28.0	8402-141	8402-241
double acting	without switch	29.0	8402-143	8402-243
2 x single acting	without switch	29.0	8402-142	8402-242
2 x double acting	without switch	30.0	8402-144	8402-244

Order

For versions with mounted oil level control switch add identification letter "T" to the **part-no.**

Example: Power unit double acting with manual switch and oil level control switch **part-no. 8402-103T**

For retrofitting **part-no. 0353-001**

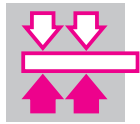

ROEMHELD

Plan of maximum terminal connections
Part-no. 8402-X4X

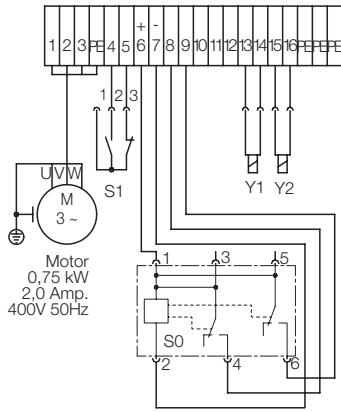

Electric circuit diagram: e.g. 2 x double acting with 2 push-button switches

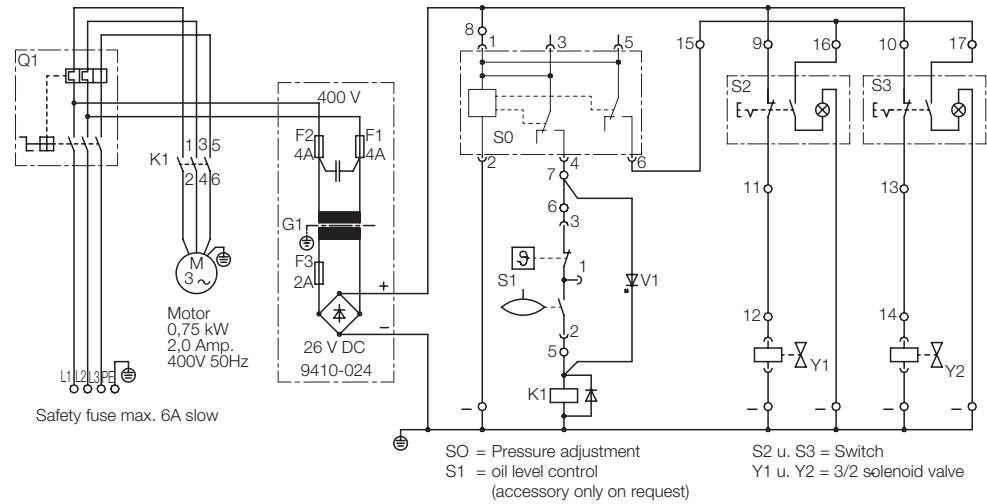

Hydraulic circuit diagrams

