

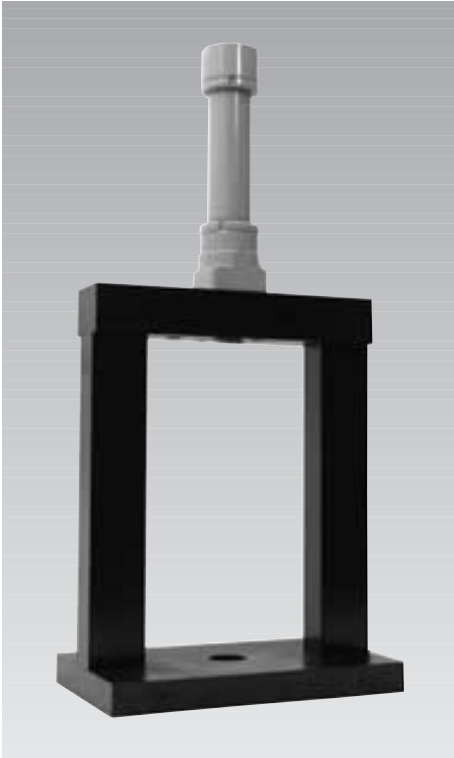

Press-In Devices 25 - 100 kN closed box-type frame design with hydro-cylinder



Advantages

- High flexibility in the operative range
- Multiple possibilities of application
- Improved ergonomics
- Simple integration in the working place
- Quality assurance in the range of application
- Short amortisation time
- Closed force-loop
- Defined force ratios
- Light component load

Industry/applications (selection)

- ◆ Drive technology, gears box assembly
- ◆ Couplings, cardan shafts
- ◆ Compressors, pumps, hydraulic elements
- ◆ Industrial fittings
- ◆ Materials-handling technology
- ◆ Automotive industry and their suppliers
- ◆ Machine tool building
- ◆ Building and agricultural machines
- ◆ Electronics

Application

The hydraulic press-in devices are preferentially used for rationalization of power-operated processes such as jointing, pressing-in, jolting, deforming, riveting, etc. In addition, rigid and closed press-in frames are frequently required.

Description

The design of the press-in fixtures is based on a base plate with concentric location hole, Ø 50 mm – H7; this hole is provided for defined fixture adjustment of the workpiece fixture to be located. The axis of the hydro-cylinder in the crosshead is concentrically aligned to the location hole. By means of precisely manufactured components the course parallel to the axis is guaranteed when operating the hydro-cylinder. The box-type frame design excels particularly by its rigid characteristics. The press-in devices meet the general standards of quality in the fixture construction.

Application and installation instructions

The CE machine tool guide lines have to be met. It has particularly to be considered that the requirements relevant for safety are met. These are for example the two-hand operation of the hydro-cylinder, protection caps in front of the working area, intrinsically safe version of the workpiece fixture to be located in the working area.

Operating conditions, tolerances and other data see data sheet A 0.100.

Hydro-cylinder as per data sheet B 1.281.

Electro-hydraulic drive units

For oil supply electro-hydraulic drive units with two-hand operating panel as per data sheet M 6.6065 or power units as per data sheet D 8.013 or D 8.018 with automatic press-in control are advantageously used.

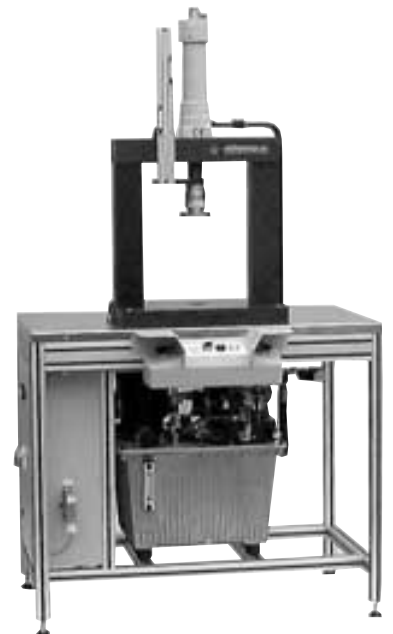

Application example with closed press-in frame and quick-change tooling system as per data sheet M 6.6055



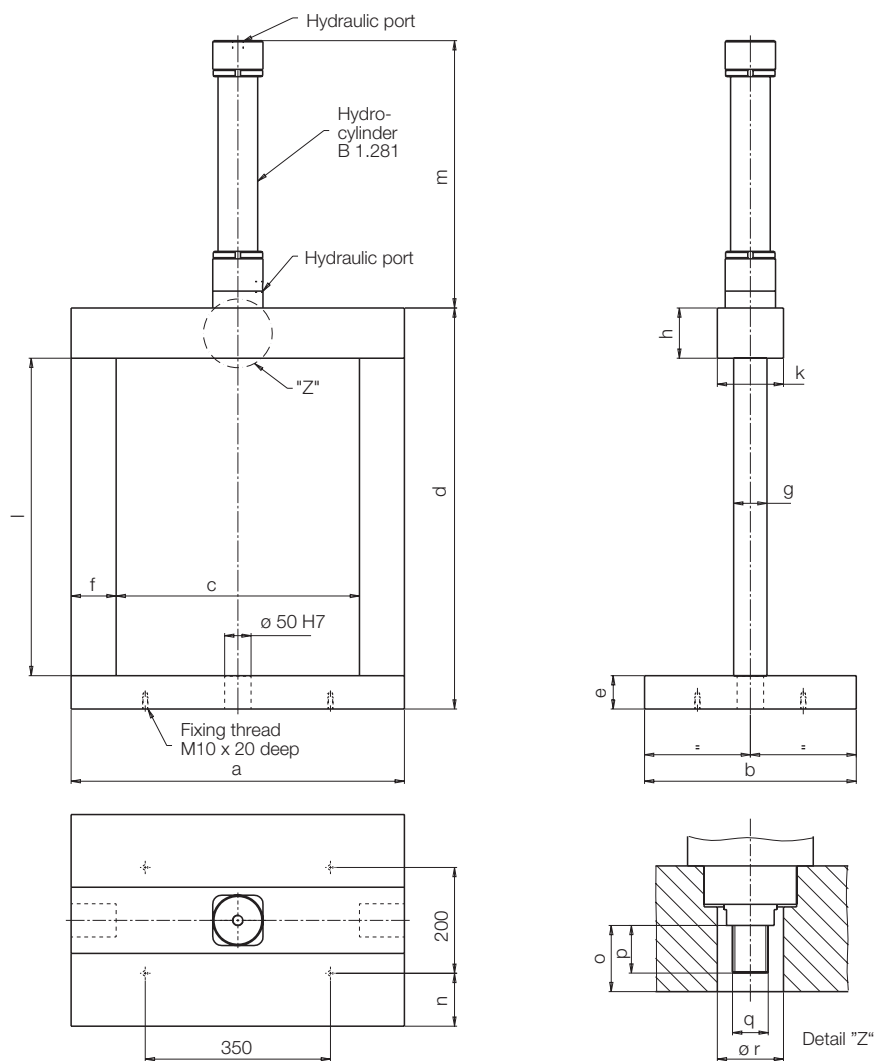

Size 1

Size 2

Size 3

Size 4

Max. force to push [kN]	25	25	40	40	63	63	100	100
with hydro-cylinder	1285-033	1285-043	1286-033	1286-043	1287-033	1287-053	1288-043	1288-063
Stroke [mm]	250	320	250	320	250	400	320	500
a [mm]	400	500	400	500	500	630	630	800
b [mm]	250	315	250	315	315	400	400	500
c [mm]	250	350	250	350	330	460	430	600
d [mm]	463	625	463	625	555	758	688	940
e [mm]	40	50	40	50	50	63	63	80
f [mm]	75	75	75	75	85	85	100	100
g [mm]	55	55	55	55	63	63	75	75
h [mm]	63	75	63	75	75	95	95	120
k [mm]	85	100	85	100	100	125	125	160
l [mm]	360	500	360	500	430	600	530	740
m [mm]	337	407	342	412	355	505	446	626
n [mm]	25	57.5	25	57.5	57.5	100	100	100
o [mm]	31	43	25	37	30	50	41	66
p [mm]	22	22	28	28	36	36	45	45
q	M 16x1.5	M 16x1.5	M 20x1.5	M 20x1.5	M 27x2	M 27x2	M 33x2	M 33x2
r [mm]	36	36	40	40	50	50	70	70
Hydraulic port	G 1/4	G 1/4	G 1/2	G 1/2	G 1/2	G 1/2	G 1/2	G 1/2
Weight [kg]	74	126	78	130	142	250	265	480
Part-no.	6600-320	6600-310	6600-321	6600-311	6600-322	6600-312	6600-323	6600-313